

MIZU BRONZE & CAST IRON VALVE

JIS 10K FOOT VALVE Grade A

Body - Bronze \varnothing 40 & \varnothing 50

- Cast Iron \varnothing 65 through \varnothing 400 inclusive

End Connection Screw \varnothing 40 through \varnothing 100 inclusive

End Connection Flange \varnothing 65 through \varnothing 400 inclusive



SIZE 40 - 100 mm



SIZE 65 - 150 mm



SIZE 200 - 400 mm

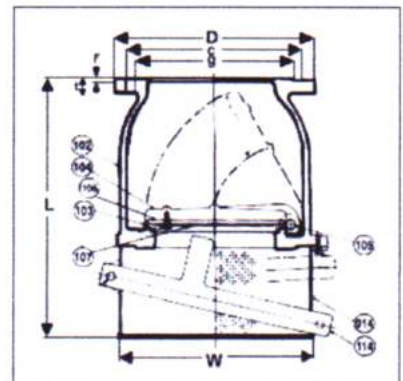
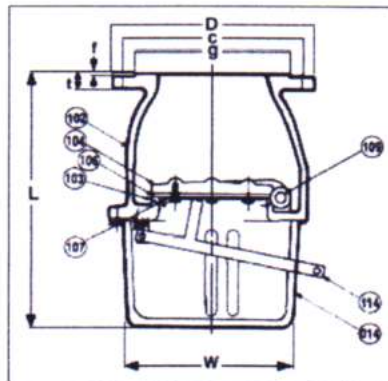
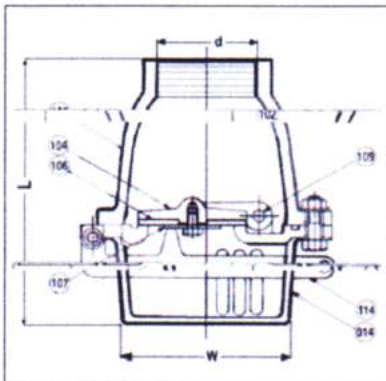

Material Description

No.	Part Name	Material			
		40 - 50	65 - 100	125 - 150	200 - 400
102	Casing	Bronze	Cast Iron	Cast Iron	Cast Iron
103	Valve Seat	Bronze	Bronze	Bronze	Cast Iron
104	Up Down Valve	Bronze	Cast Iron	Cast Iron	Cast Iron
106	Seat Packing	NR (Silicon **)	NR (Silicon **)	NR (Silicon **)	NR (Silicon **)
107	Plate	Stainless Steel	Stainless Steel	Stainless Steel	Steel Plate
109	Pin	Stainless Steel	Stainless Steel	Stainless Steel	Stainless Steel
114	Lever Handle	Stainless Steel	Stainless Steel	Steel Plate	Steel Plate
014	Strainer	Stainless Steel	Stainless Steel	Stainless Steel	Stainless Steel

◆ Other materials are available on request (**)= Silicon rubber packing. For mineral oils application only.

Technical Specification

Size	inch	1½	2	2½	3	4	2½	3	4	5	6	8	10	12	14	16
	mm	40	50	65	80	100	65	80	100	125	150	200	250	300	350	400
CONT	Screw						Flange									
L	185	193	220	254	303		215	252	302	312	366	465	506	613	765	915
W	84	95	118	126	152		118	126	152	195	227	320	380	433	547	640
d	PT.1½	PT.2	PT.2½	PT.3	PT.4											
D							175	185	210	250	280	330	400	450	490	570
C							140	150	175	210	240	290	355	397	445	515
g							120	130	155	185	215	265	325	365	415	470
t							17	17	17	22	22	24	26	32	34	37
F							2	2	2	2	2	2	2	2	5	5
Weight (Kgs)	3	4	5.5	7.5	11		10	12	19	26	34	62	82	128	187	294

◆◆ Dimensions and technical data are subjected to change without notice

MIZU BRONZE & CAST IRON VALVE

JIS 10K FOOT VALVE Grade B



Body - Bronze \varnothing 40 & \varnothing 50
 - Cast Iron \varnothing 65 through 500 inclusive
 End Connection Screw \varnothing 40 through 100 inclusive
 End Connection Flange \varnothing 65 through 500 inclusive



SIZE 40 -100 mm



SIZE 65 - 150 mm



SIZE 200 - 500 mm

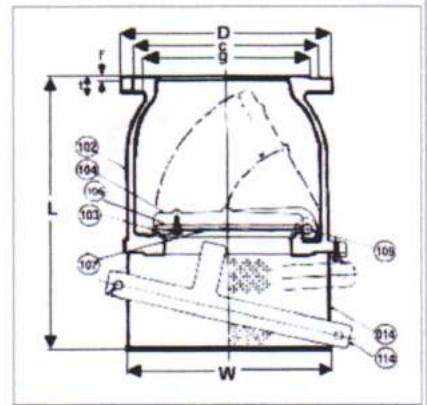
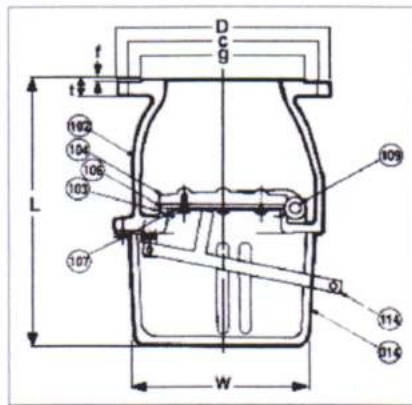
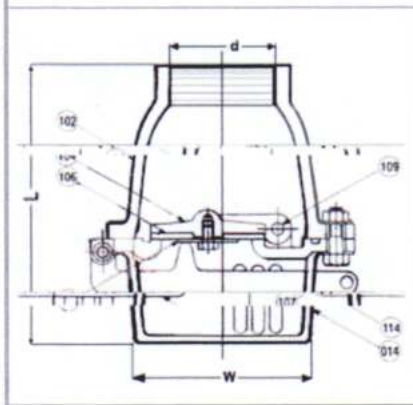

Material Description

No.	Part Name	Material			
		40-50	65-100	125-150	200-500
102	Casing	Cast Iron	Cast Iron	Cast Iron	Cast Iron
103	Valve Seat	Bronze	Bronze	Bronze	Cast Iron
104	Up Down Valve	Cast Iron	Cast Iron	Cast Iron	Cast Iron
106	Seat Packing	NR (Silicon **)	NR (Silicon **)	NR (Silicon **)	NR (Silicon **)
107	Plate	Steel Plate Chrome	Steel Plate Chrome	Steel Plate	Steel Plate
109	Pin	Stainless Steel	Stainless Steel	Stainless Steel	Stainless Steel
114	Lever Handle	Steel Plate Chrome	Steel Plate Chrome	Steel Plate	Steel Plate
014	Strainer	Steel Plate Chrome	Steel Plate Chrome	Steel Plate Chrome	Steel Plate Chrome

* Other materials are available on request (**)= Silicon rubber packing. For mineral oils application only.

Technical Specification

Size	inch	1 1/2	2	2 1/2	3	4	2 1/2	3	4	5	6	8	10	12	14	16	18	20	
	mm	40	50	65	80	100	65	80	100	125	150	200	250	300	350	400	450	500	
CONT		Screw						Flange											
L		185	193	220	254	303	215	252	302	312	366	465	506	613	765	915	1060	1075	
W		84	95	118	126	152	118	126	152	195	227	320	380	433	547	640	690	705	
d		PT.1 1/2	PT.2	PT.2 1/2	PT.3	PT.4													
D							175	185	210	250	280	330	400	450	490	570	620	635	
C							140	150	175	210	240	290	355	397	445	515	560	575	
g							120	130	155	185	215	265	325	365	415	470	470	485	
t							17	17	17	22	22	24	26	32	34	37	37	52	
F							2	2	2	2	2	2	2	2	5	5	5	5	
Weight (Kgs)		3	4	5.5	7.5	11	10	12	19	26	34	62	82	128	187	294	310	356	

** Dimensions and technical data are subjected to change without notice