

# EBARA GEAR PUMPS

## MODEL GP

### APPLICATIONS

Supplying oil for machinery  
 Fuel transfer  
 Low pressure transmission  
 Oil burner injection

### FEATURES

Compact style and light weight  
 Adopting high speed and direct drive type, relieving traditional image of gear pumps  
 Large capacity with small power output  
 Long life and high reliability  
 Durability increased by adopting needle bearings and maintenance made easy by using internal bearings, requiring no oil supply  
 Quick delivery and low price  
 Adjustable relief valve

### SPECIFICATIONS

Model	MODEL GPE	MODEL GPF	MODEL GPH
Suction & Discharge size	12 to 25 mm ( $\frac{3}{8}$ to 1 inch)	12 to 40 mm ( $\frac{3}{8}$ to $1\frac{1}{2}$ inches)	15 to 50 mm ( $\frac{1}{2}$ to 2 inches)
Discharge pressure	3 kgf/cm <sup>2</sup> (43PSI) {290 kPa}	3 to 10 kgf/cm <sup>2</sup> (43 to 142PSI) {290 to 980 kPa}	10 to 20 kgf/cm <sup>2</sup> (142 to 284PSI) {980 to 1960 kPa}
Allowable suction pressure	-0.3 to +1.0 kgf/cm <sup>2</sup> (-4.3 to +14.2PSI) {-29 to +98 kPa}	-0.5 to +1.0 kgf/cm <sup>2</sup> (-7.1 to +14.2PSI) {-49 to +98 kPa}	-0.5 to +1.0 kgf/cm <sup>2</sup> (-7.1 to +14.2PSI) {-49 to +98 kPa}
Temperature limit	70°C(158°F)	80°C(176°F)	120°C(248°F)
Viscosity range for motor with standard output & speed	7 to 500 cSt {7 to 500 mm <sup>2</sup> /s}	5 to 500 cSt {5 to 500 mm <sup>2</sup> /s}	5 to 260 cSt {5 to 260 mm <sup>2</sup> /s}

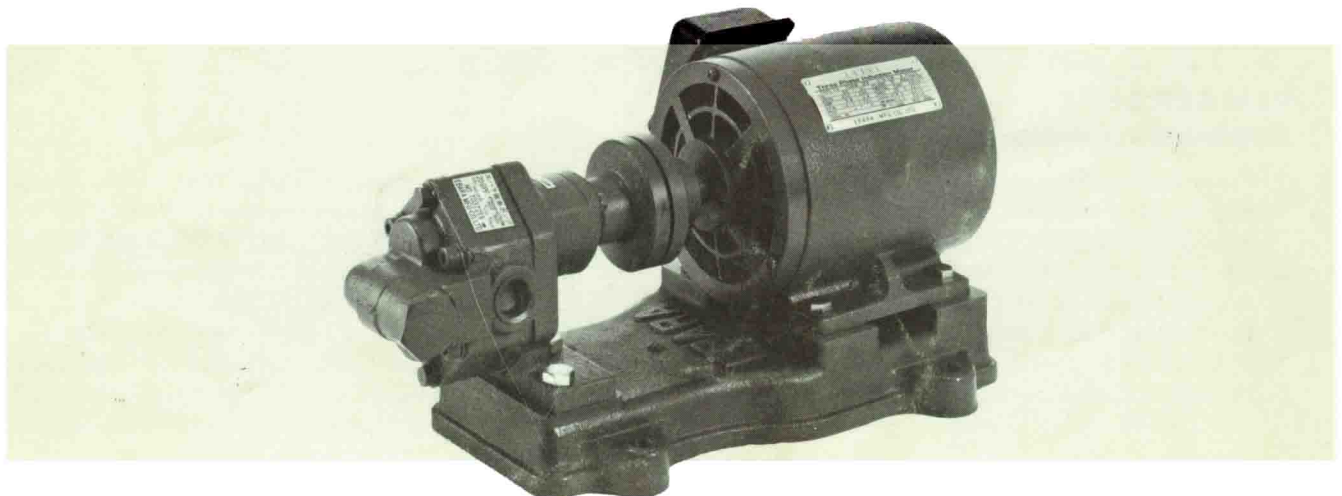

## PERFORMANCE TABLE

### Model GPE (Discharge pressure 3 kgf/cm<sup>2</sup> {290 kPa})

Size	Pipe connecting	Motor kW	50 Hz			60 Hz			Bearing size	Gland		Weight {Mass} kg	
			Max. Discharge pressure kgf/cm <sup>2</sup> {kPa}	Capacity ℓ/min	Speed min <sup>-1</sup>	Max. Discharge pressure kgf/cm <sup>2</sup> {kPa}	Capacity ℓ/min	Speed min <sup>-1</sup>		Kind	Shaft size	Bare pump	Pump w/motor & base
12	PT-3/8	0.2	3 290	7	1500	3 290	6	1800	8φ	Packing	8φ	2	18.4
15	PT-1/2	0.4	3 290	10	1500	3 290	12	1800	12φ	"	11φ	2.1	19.2
20	PT-3/4	0.4	3 290	20	1500	3 290	24	1800	12φ	"	11φ	2.4	21.4
25	PT-1	0.75	3 290	40	1500	3 290	48	1800	15φ	"	14φ	4	35.1

### Model GPF (Discharge pressure 3 ~ 10 kgf/cm<sup>2</sup> {290 ~ 980 kPa})

12	PT-3/8	0.2	4 390	8.5	1500	4 390	10	1800	12φ (With inside ring)	Mechanical seal	12φ	3.1	20.1
		0.4	10 980	8.5	1500	10 980	10	1800				23.1	
15	PT-1/2	0.4	4 390	17	1500	4 390	21	1800	12φ (With inside ring)	"	12φ	3.4	22.4
		0.75	10 980	17	1500	10 980	21	1800				33.4	
20	PT-3/4	0.75	4 390	31	1500	4 390	37	1800	20φ (With inside ring)	"	20φ	6.0	37.3
		1.5	10 980	31	1500	10 980	37	1800				43.3	
25	PT-1	1.5	6 590	54	1500	6 590	65	1800	20φ (With inside ring)	"	20φ	6.3	44.3
		2.2	10 980	54	1500	10 980	65	1800				61.5	
32	PT-1 1/4	2.2	4 390	75	1500	4 390	90	1800	22φ (With inside ring)	"	22φ	11	68
		3.7	10 980	75	1500	10 980	90	1800				77.2	
40	PT-1 1/2	2.2	6 590	105	1500				22φ (With inside ring)	"	22φ		69
		3.7	10 980	105	1500							79	
		3.7				4 390	125	1800				79	
		5.5	10 980			10 980	125	1800					116

### Model GPH (Discharge pressure 10 ~ 20 kgf/cm<sup>2</sup> {980 ~ 1960 kPa})

15	PS-1/2	0.75	15 1470	14	1500	12 1180	18	1800	15φ (With inside ring)	Mechanical seal	14φ	7	31
		1.5	20 1960	13	1500	20 1960	16	1800				38	
20	PS-3/4	1.5	12 1180	36	1500	12 1180	43	1800	20φ (With inside ring)	"	14φ	8	39
		2.2	20 1960	34	1500	20 1960	41	1800				54	
25	PS-1	3.7	15 1470	70	1500	15 1470	85	1800	25φ (With inside ring)	"	22φ	12	60
		5.5	20 1960	69	1500	20 1960	84	1800				86	
32	32φ JIS 20 kgf/cm <sup>2</sup> Flange	5.5	15 1470	110	1500	12 1180	136	1800	25φ (With inside ring)	"	22φ	20	97
		7.5	20 1960	110	1500	20 1960	134	1800				112	
40	40φ JIS 20 kgf/cm <sup>2</sup> Flange	5.5				12 1180	142	1200	35φ (With inside ring)	"	30φ		123
		7.5	15 1470	174	1500	20 1960	139	1200				121	
50	50φ JIS 20 kgf/cm <sup>2</sup> Flange	11	15 1470	184	1000	15 1470	224	1200	40φ (With inside ring)	"	35φ	37	191
		15	20 1960	184	1000	20 1960	220	1200				241	

### REMARKS:

- Pipe connections are Pipe Taper Thread (JIS B0203) for Model GPE and GPF and Pipe Straight Thread (JIS B0203) for Model GPH.
- Flange connection of Model GPH is as per pipe flange dimension of JIS B2214.
- Base dimension is based on dimension of JEM 1180 Class E motor.
- Rotating direction shall be clockwise viewed from motor side. Suction opening shall be located at left side and delivery opening at right side. The opposite structure shall be obtained by simple re-assembly work.
- Model GPE adopts packing seal, while Model GPF and GPH adopts mechanical seal.
- Needle bearings are used. Please be noticed to nominate bearings with inside rings for Model GPF and GPH in case of parts order.
- Special parts for adjusting working pressure of relief valves for Model GPE and GPF are available upon special request. Working pressure of relief valve for Model GPH can be adjusted with adjusting nut built in the valve.

# DIMENSIONS

## MODEL GPE

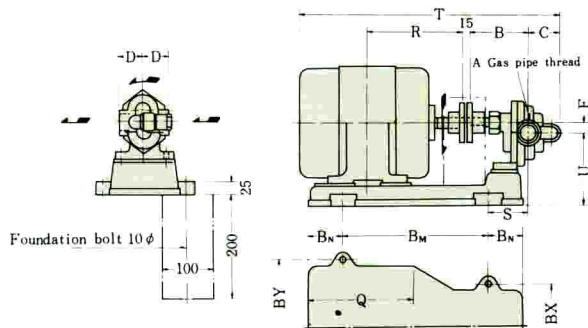

(DIMENSIONS IN mm)

Size	Model	kW	A	B	C	D	F	BM	BN	BY	BX	R	S	T	U
12	GPEM	0.2	PT- $\frac{3}{8}$	90	50	40	12.5	160	60	180	138	103	64	370	90.5
15	GPEM	0.4	PT- $\frac{1}{2}$	100	50	40	12	180	60	194	138	120	65	400	96
20	GPEM	0.4	PT- $\frac{3}{4}$	105	55	40	15	180	60	194	138	120	70	410	96
25	GPEM	0.75	PT-1	117	66	50	20	220	60	214	168	140	70	434	115

## MODEL GPF

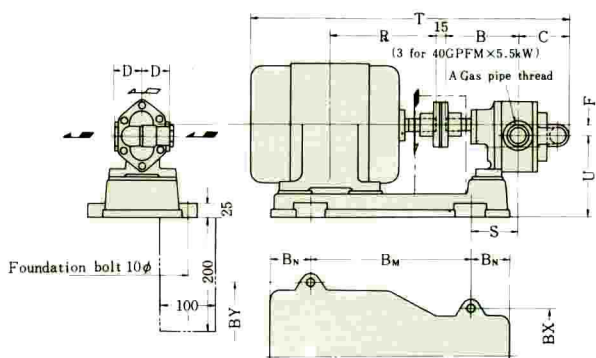

(DIMENSIONS IN mm)

Size	Model	kW	A	B	C	D	F	BM	BN	BY	BX	R	S	T	U
12	GPFM	0.2	PT- $\frac{3}{8}$	98	60	40	15	160	60	180	138	103	63	388	96
		0.4						180	60	194	138	120	63	408	96
15	GPFM	0.4	PT- $\frac{1}{2}$	103	65	40	15	180	60	194	138	120	68	418	96
		0.75						210	60	214	138	140	68	420	110
20	GPFM	0.75	PT- $\frac{3}{4}$	112	81	50	20	220	60	214	168	140	65	445	115
		1.5						260	60	232	168	168.5	65	492	115
25	GPFM	1.5	PT-1	120	89	50	20	260	60	232	168	168.5	73	508	115
		2.2						270	70	264	168	183	83	537	125
32	GPFM	2.2	PT-1 $\frac{1}{4}$	156	102	60	25	280	80	264	194	183	95	586	145
		3.7						300	80	290	194	200	95	610	145
40	GPFM	2.2	PT-1 $\frac{1}{2}$	162	108	60	25	280	80	264	194	183	101	598	145
		3.7						300	80	290	194	200	101	622	145
		5.5						310	90	320	194	239	111	665	162

## MODEL GPH

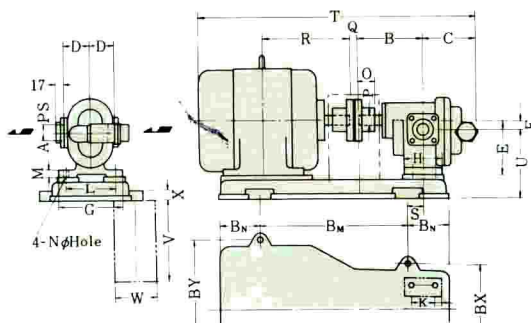

Screw type inlet & outlet for  $\phi$ 25mm or less.  
Flange type inlet & outlet for  $\phi$ 32mm or more

(DIMENSIONS IN mm)

Size	Model	kW	Speed min <sup>-1</sup>		A	B	C	D	F	G	H	K	L	M	N	O	P	Q	BM	BN	BY	BX	R	S	T	U
			50Hz	60Hz																						
15	GPHM	0.75	1 500	1 800	PS- $\frac{1}{2}$	110	90	45	15	120	70	35	90	14	12	35.5	14	15	260	70	214	175	140	30	480	125
																			290	80	232	175	168.5	30	498	125
20	GPHM	1.5	1 500	1 800	PS- $\frac{3}{4}$	130	90	50	15	120	70	35	90	14	12	40	14	15	290	80	232	175	168.5	40	518	125
																			310	80	264	175	183	40	548	135
25	GPHM	3.7	1 500	1 800	PS-1	160	120	55	20	140	80	50	110	16	12	50	22	15	330	100	290	195	200	45	630	145
																			370	100	320	195	239	45	674	162
32	GPHM	5.5	1 500	1 800	32	175	128	95	20	170	120	90	130	16	12	50	22	3	400	120	320	225	239	45	697	162
																			400	120	320	225	258	45	736	162
40	GPHM	7.5	1 500	1 800	40	160	143	110	25	200	120	90	150	16	15	63	28	3	380	150	320	255	258	75	766	195
																			380	150	320	255	258	75	766	195
50	GPHM	11	1 500	1 200	40	160	143	110	25	200	120	90	150	16	15	63	28	3	510	150	380	260	323	75	862	205
																			510	150	380	260	323	75	862	205
50	GPHM	15	1 000	1 200	50	220	160	120	30	200	120	90	150	16	15	63	35	3	510	150	380	260	345	75	951	200
																			560	150	430	260	370.5	75	1.011	220



# ACCESSORIES

## SUCTION STRAINER

### DIMENSIONS OF SUCTION STRAINER

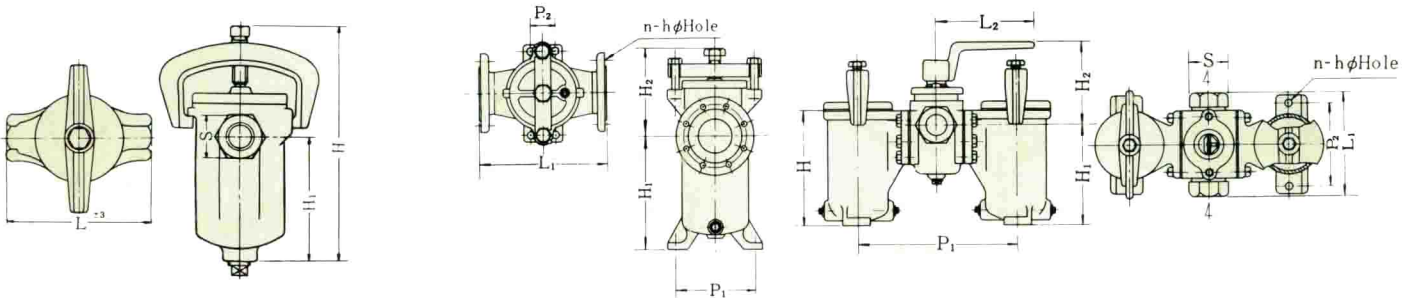

Model STU Single strainer  
(Size 15—φ40mm)

Model STU Single strainer  
(Size φ50mm or more, Flange JIS 10kgf/cm<sup>2</sup> FF)

Model STW duplex strainer  
(Size 15 ~ φ40mm)

Model	Connection size	H	H <sub>1</sub>	H <sub>2</sub>	L <sub>1</sub>	L <sub>2</sub>	P <sub>1</sub>	P <sub>2</sub>	S	nh	Weight Mass   kg
STU 15	½ B	167	84		120					35	2.5
STU 20	¾ B	239	135		170					41	3.6
STU 25	1 B	239	135		150					50	3.6
STU 32	1¼ B	330	200		235					63	10
STU 40	1½ B	330	200		210					71	10
STU 50	2 B		195	142	250		150	50		4.19	21
STW 15	½ B	107	92	83	120	120	125	90	35	4.11	6.4
STW 20	¾ B	165	145	115	150	150	215	120	50	2.11	14.5
STW 25	1 B	165	145	115	150	150	215	120	50	2.11	14.5
STW 32	1¼ B	226	195	121	175	180	250	120	67	2.15	20.5
STW 40	1½ B	257	220	126	210	200	265	130	71	2.15	30.5

**Remarks :**

Mesh 60

Effective filtration area : Size 15 ~ φ40mm  
more than 8 times of strainer size  
Size φ50mm or larger  
more than 5 times of strainer size

Hydro test press. of case : 6 kgf/cm<sup>2</sup>(85PSI) | 590kPa

Max allowable normal press : 3 kgf/cm<sup>2</sup>(43PSI) | 290kPa

### STRAINER-CAPACITY VISCOSITY-RESISTANCE CURVE

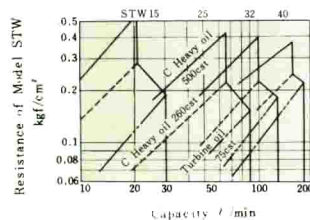
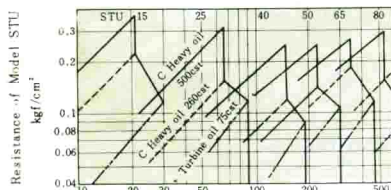

\* 1kgf/cm<sup>2</sup> = 98.0665kPa

**Remarks :**

- 1 Make 20% allowance for the above values, as these values may vary in accordance with oil qualities
- 2 Suitable strainer resistance value shall be taken at less than 0.3kgf/cm<sup>2</sup>
- 3 Add strainer friction loss to suction lift

### VISCOSITY CHART OF OILS

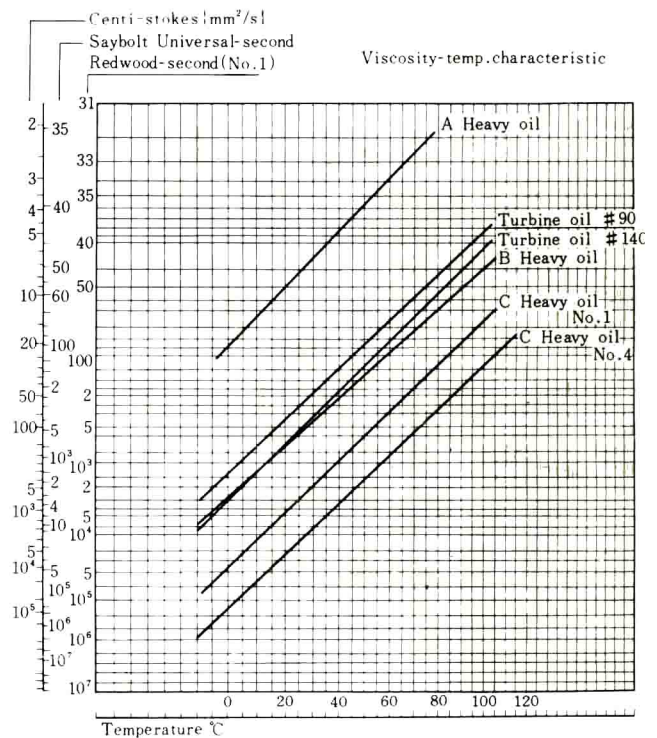

\*Features and specifications subject to change without notice.

In this catalog, the particulars in { } are in accordance with the international system of units (SI) and given for reference only.