

KRACHT®

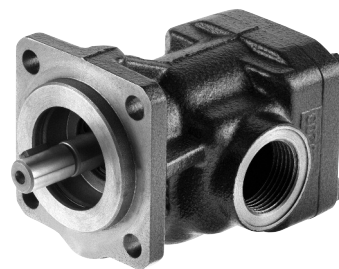

Gear Pumps

KF 2.5...630

Contents

Technical Data

	Page
Applications/Suitable fluids	3
Construction	4
Variants/Direction of rotation	5
ATEX version	5
Materials/Characteristics	6
Shaft end seals/Variants Shaft End Seals	7 – 8
Version noise optimized	9
Type key	10 – 11
Technical data	12
Discharge flow/Input power	13 – 15

Dimension Sheets

Flange-mounting version with pipe thread	Nominal size 2.5 – 25 ...	16
Flange-mounting version with SAE-connection	Nominal size 2.5 – 630 ..	17
Pump with mounting angle, pipe thread	Nominal size 2.5 – 25 ...	18
Pump with mounting angle, SAE 1½-connection	Nominal size 32 – 80 ...	18
Flange-mounting version with universal valve U2	Nominal size 32 – 80 ...	19
Flange-mounting version with universal valve U2	Nominal size 100/112 ...	20
Couplings and bell housing		21
Motor-pump assemblies with pipe thread	Nominal size 2.5 – 25 ...	22 – 23
Motor-pump assemblies with SAE-connection	Nominal size 32 – 80 ...	24 – 25
Motor-pump assemblies with SAE-connection	Nominal size 100 – 200 ...	26 – 27
Motor-pump assemblies with SAE-connection	Nominal size 250 – 630 ...	28 – 29
Threaded flange / Welding flange		30

Applications, Suitable Fluids

Applications

Centrifuge construction,
Coating machines, Compressors

Engine construction

Filling stations, Filter systems

Generator construction

Heat transfer systems, Heavy electrical machines

Lubricant manufacturers, Lubricating oil systems

Machine-building industry, Machine tools,
Manufacture of apparatus,
Marine engine construction,
Metal-forming machines, Metering systems

Paint industry, Plain metal bearing production,
Printing machines, PUR machinery

Refrigerators, Rubber and tire manufacturing

Tank plant construction,
Transmission building
Turbine construction

Vacuum machinery

Waste oil - disposal
- transport
- treatment

Suitable fluids

Adhesives, Antifreeze

Bore oils

Cutting oils

Diesel oils, Drawing compound

Emulsions

Fuel oils, L, EL, H

Gear oils, Grease

Hardening oils, Heat transfer media,
Heavy oils, Hydraulic fluids

Isocyanate

Lubricating oils, Lacquers

Motor oils

Paint, Paraffins, Plastics, Polyols

Printing inks, Processing oils

Resins, Rolling oils

Waste oils, Waxes

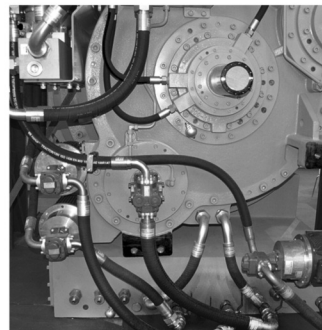
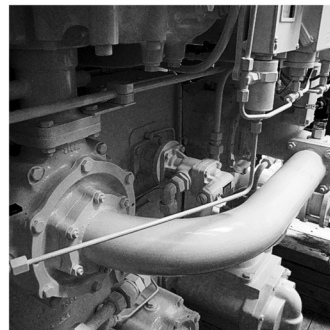
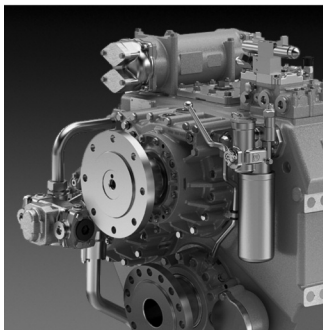
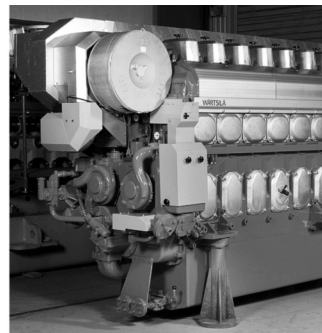

Construction

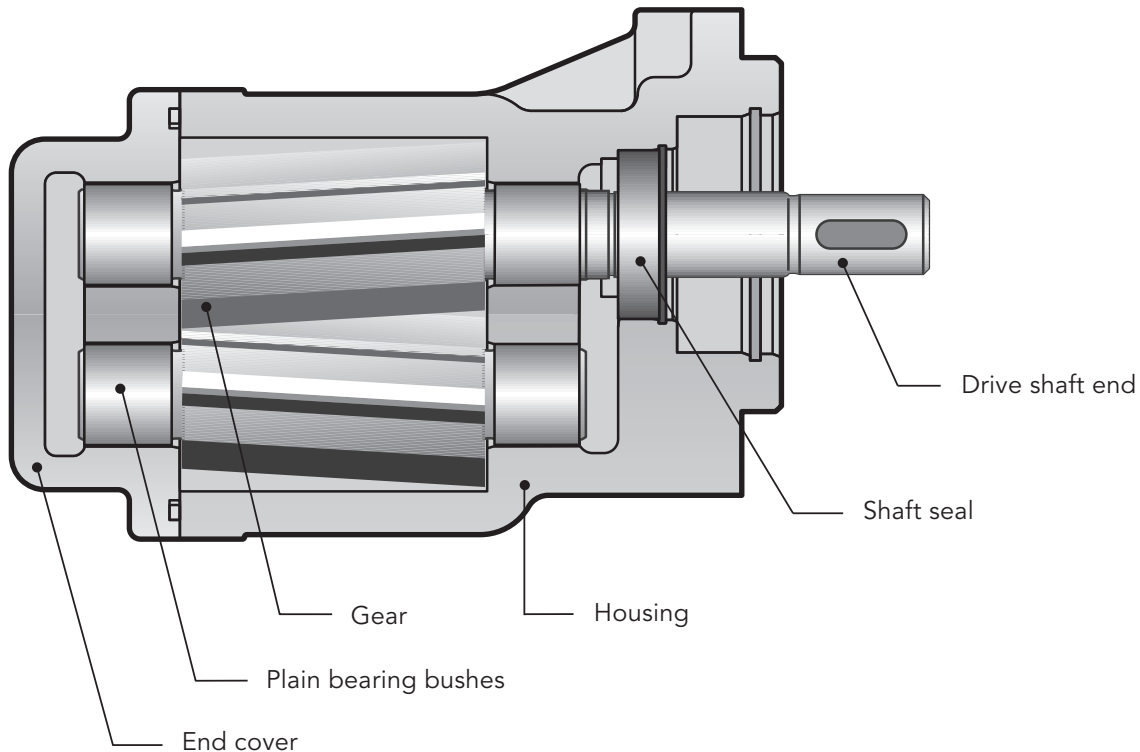

Product Features

Gear pumps KF are used for pumping a wide variety of fluids.

Gear pumps KF are distinguished especially by their wide range of variants which are assembled as required on the modular principle and also permit subsequent upgrade.

The pumps are also suitable for media with low lubricating properties.

The standard housing sections are of grey cast iron.

The gear units are manufactured from high-strength case-hardening steel, hardened and mounted in special multi-compound plain bearing bushes.

The standard drive shaft is sealed by single radial lip-type seal.

All pump sizes incorporate helical tooth system. This feature, combined with special gear geometry, results in extremely low noise levels and reduced pressure pulsation.

Working Notes

- The fluids should ensure a certain minimum lubricating properties, should not contain solids and should be chemically compatible.
- Avoid dry operation.
- The pumps may only be operated in the specified direction of rotation, as otherwise the shaft seal will be destroyed.
- In order to prevent excessive overpressure, a safety valve should be provided in the system or on the pump.
- The pressure relief valve attached to the pump may only be used as safety valve for short-term operation.
- A separate pressure relief valve with return line to the reservoir must be foreseen, if a partial discharge flow has to be drained over a prolonged period.

Variants

- Sealing of the drive shaft:
 - Single radial lip-type seal
 - Double radial lip-type seal (Quench)
 - Mechanical seal
- Outboard bearing to take up input drive-side radial load
- Pressure valve for pump and system
- Uniform discharge flow direction with changing direction of rotation by means of flange-mounting valve combination (universal valve).

Special Design

Various shafts ends and gear units, as well as flange mounted versions, bearing alternatives, multi-stage pump combinations for your special application are available on request.

Our Sales engineers will be pleased to advise you.

Accessories

- Connecting flanges
- Couplings
- Bell housing
- Quench tank
- Attenuation elements

ATEX-Version

	KF 2.5...200 with lip-type seal	KF 2.5...200 with double lip-type seal
In Ex-area max. suitable for category	II 2GD ck IIC/IIIB TX	II 2G ck IIC TX
Perm. working pressure inlet port in bar/psi	- 0.4 ... 0.5 / -5.8 ... 7.3	- 0.4 ... 0.5 / -5.8 ... 7.3
Perm. differential pressure in bar/psi	see page 6 „permissible differential pressure“	see page 6 „permissible differential pressure“
Perm. viscosity in cSt	12 ... 20 000	12 ... 20 000
Max. speed in rpm (viscosity dependent)	see page 6 „speed“	see page 6 „speed“
Perm. mounting position	Horizontal or shaft end toward bottom	Horizontal quencher up
Perm. media temperatures in °C/°F	-20 ... 80 / -4 ... 176 – NBR (T4) -15 ... 80 / 5 ... 176 – FKM (T4) -15 ... 110 / 5 ... 230 – FKM (T3)	-20 ... 80 / -4 ... 176 – NBR (T4) -15 ... 80 / 5 ... 176 – FKM (T4) -15 ... 110 / 5 ... 230 – FKM (T3)
Perm. ambient temperatures in °C/°F	-20 ... 60 / -4 ... 140 – NBR -15 ... 60 / 5 ... 140 – FKM	-20 ... 60 / -4 ... 140 – NBR -15 ... 60 / 5 ... 140 – FKM
Comments	Vertical mounting with shaft end up on request. In executing with outboard bearing max. speed 1500 rpm In dust Ex-area, permissible only with non-conductive dusts.	Not suitable for dust-Ex. Execution with quench feed and quencher.

Additional products available on request.

Direction of Rotation

The following should be note for direction of rotation:

- when looking at the pump shaft end, the direction of pumping is from left to right if the shaft rotates **clockwise**.
- when looking at the pump shaft end, the direction of pumping is from right to left if the shaft rotates **counterclockwise**.

Without pressure relief valve

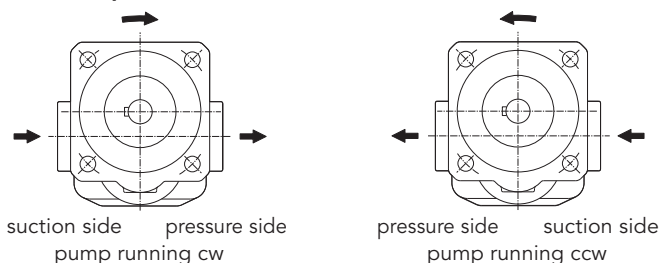

With pressure relief valve

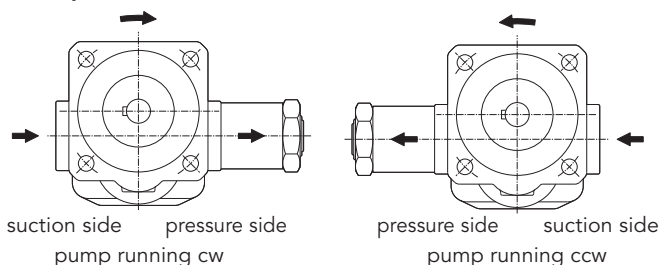

With universal valve

Direction of rotation right and left

Direction of rotation consistent, see dimension sheets page 19 to 20.

Materials

Housing and cover	EN-GJL-250 (GG 25) EN-GJS-400-15 (GGG 40)
Gear	Steel 1.7139
Plain bearing bushes	DU (multi-layer friction-type bearings P 10, DP 4) Bearings free of nonferrous metal on request
Shaft seals	Single radial lip-type seals: NBR, FKM, PTFE, EPDM, low temperature FKM Mechanical seal
O-ring	NBR, FKM, PTFE, EPDM, low temperature FKM (other sealing materials on request. E.g. HNBR/CR)

Characteristics

Nominal sizes 2.5...630 cm ³ /r	2.5 / 4 / 5 / 6 / 8 / 10 / 12 / 16 / 20 / 25 / 32 / 40 / 50 / 63 / 80 / 100 / 112 / 125 / 150 / 180 / 200 / 250 / 315 / 400 / 500 / 630	
Mounting position	KF ... R/L/B ... without Quench optional KF ... R/L/B ... with Quench horizontal, Quench connection above KF ... U2 ... optional	
Direction of rotation	right or left right and left	
Fixing type	flange	
Pipe connection	KF 2.5...25 KF 32...630	Whitworth pipe thread, SAE flange SAE flange
Drive shaft end	ISO R 775 short-cylindrical	
Working pressure suction side	see chart page 7	
Working pressure pressure side	P _n max. 25 bar / 363 psi (higher pressures on request, see chart „permissible differential pressure“)	
Speed	KF 2.5...63 200 ... 3 600 rpm KF 80...180 200 ... 3 000 rpm KF 200 200 ... 2 500 rpm KF 250...630 200 ... 2 000 rpm	
Recommended speed	The speed of the pump must be chosen in such a way that complete pump filling is guaranteed. This is given if the relative pressure at the pump inlet does not fall below -0.4 bar/-5.8 psi (-0.6 bar / -8.7 psi briefly e.g. during cold start).	
Viscosity (dependent on pressure and rotational speed)	V _{min} V _{max}	1.4... 12 cSt (see chart "permissible differential pressure") 20 000 cSt (higher viscosities on request)
Fluid temperature	see chart „permissible temperatures“	
Ambient temperature	see chart „permissible temperatures“	

Permissible Differential Pressure

Bearing	Δp _{max} [bar/psi]		
	≥ 1.4 cSt	≥ 6 cSt	≥ 12 cSt
Multi-layer plain bearing containing lead ⁽¹⁾ : DU®, P10	3 / 44	12 / 174	25 / 363
Multi-layer plain bearing lead-free ⁽²⁾ : DP4			
Plastic plain bearing ⁽²⁾ : Iglidur® X	-	6 / 87	10 / 145
White metal plain bearing ⁽²⁾			

(1) Standard (2) Is defined in the special number

Shaft Seals Standard Operation

	Sealing material	Speed [rpm]	Pressure suction side (short term during start-up status: -0.6 bar / -8.7 psi)			
			KF 2.5 ... 80	KF 100 ... 200	KF 250 ... 315	KF 400 ... 630
Single radial lip-type seal	NBR / FKM	max. 750	-0.4 ... 6.0/-5.8 ... 87.0	-0.4 ... 6.0/-5.8 ... 87.0	-0.4 ... 5.5/-5.8 ... 79.8	-0.4 ... 5.0/-5.8 ... 72.5
Outboard bearing with single radial lip-type seal		max. 1000	-0.4 ... 5.0/-5.8 ... 72.5	-0.4 ... 5.0/-5.8 ... 72.5	-0.4 ... 4.5/-5.8 ... 65.3	-0.4 ... 4.0/-5.8 ... 58.0
		max. 1500	-0.4 ... 4.0/-5.8 ... 58.0	-0.4 ... 3.5/-5.8 ... 50.8	-0.4 ... 3.0/-5.8 ... 43.5	-0.4 ... 2.5/-5.8 ... 36.3
		max. 2000	-0.4 ... 3.0/-5.8 ... 43.5	-0.4 ... 2.5/-5.8 ... 36.3	-0.4 ... 2.0/-5.8 ... 29.0	-0.4 ... 1.5/-5.8 ... 21.8
		max. 3000 *	-0.4 ... 2.0/-5.8 ... 29.0	-0.4 ... 1.5/-5.8 ... 21.8	-	-
	max. 3600 **	-0.4 ... 1.5/-5.8 ... 21.8	-	-	-	
Double radial lip-type seal with connection possibility for quench	FKM (low temperature)		-0.4 ... 0.5/-5.8 ... 7.3			
	EPDM		-0.4 ... 0.5/-5.8 ... 7.3			
	PTFE		-0.4 ... 2.0/-5.8 ... 29.0			
Mechanical seal	FKM / PTFE / EPDM		-0.4 ... 10.0/-5.8 ... 145.0			
Mechanical seal with connection possibility for quench	FKM		-0.4 ... 10.0/-5.8 ... 145.0			

* KF 80 ...180

**KF 2.5 ... 63

Shaft Seals Vacuum Operation

	Sealing material	Pressure suction side (short term during start-up status: -0.6 bar / -8.7 psi)
Double radial lip-type seal for vacuum operation with connection possibility for quench	NBR / FKM / PTFE	-0.9 ... 0.2/-13.1 ... 2.9

The indicated maximum values are dependent upon the remaining working conditions.

In case of universal valves, pay attention to limitation of Pe min.

Note vacuum operation: The tank installation must be above the suction connection.

Other sealing materials on request.

Permissible Temperatures

Media temperature		Ambient temperature		Sealing material
9m min [°C/°F]	9m max [°C/°F]	9m min [°C/°F]	9m max [°C/°F]	
-20/-4	90/194	-20/-4	60/140	NBR
	200/392			PTFE / FEP with FKM core
	120/248			EPDM
-20/-4	150/302	-20/-4		FKM
	200/392			FFKM / FEP with FKM core
-30*/-22*	150/302	-30*/-22*		

* only in connection with housing and cover material EN-GJS-400 (GGG 40), -40 °C / -40 °F at standstill.

Variants Shaft End Seals

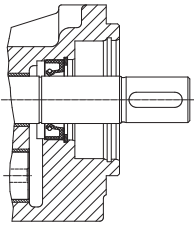

Pump with single radial lip-type seal

Fixing type: F/W

Sealing materials:

NBR = sealing type 1
 FKM = sealing type 2
 PTFE = sealing type 3
 EPDM = sealing type 9
 FKM low temperature
 = sealing type 23/31

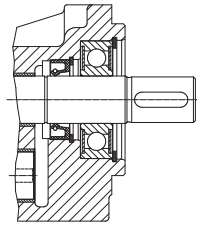

Pump with outboard bearing and single radial lip-type seal

Fixing type: G/X

Sealing materials:

NBR = sealing type 1
 FKM = sealing type 2
 PTFE = sealing type 3

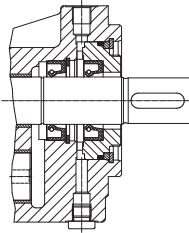

Pump with double radial lip-type seal with connection possibility for quench

Fixing type: F/W

Sealing materials:

NBR = sealing type 19
 FKM = sealing type 7
 PTFE = sealing type 4
 EPDM = sealing type 32

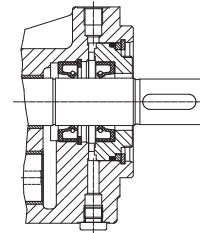

Pump with double radial lip-type seal for vacuum operation with connection possibility for quench

Fixing type: F/W

Sealing materials:

NBR = sealing type 19
 FKM = sealing type 7
 PTFE = sealing type 4
 EPDM = sealing type 32
 Special number: 74

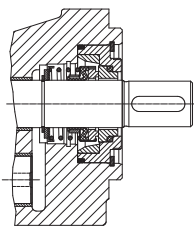

Pump with mechanical seal

Fixing type: F/W

Sealing materials:

FKM = sealing type 5 and 40
 PTFE = sealing type 6

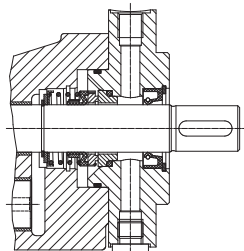

Pump with mechanical seal and connection possibility for quench

Fixing type: F/W

Sealing materials:

FKM = sealing type 5
 Special number: 198

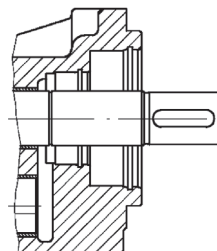

Pump without shaft sealing

Fixing type: F/W

Sealing material:

FKM o-ring = sealing type 30
 NBR o-ring = sealing type 36

KF 2.5...630 noise optimized for medias with increased air percentage

The noise optimized pumps in the KF series are designed for conveying for medias with increased air content, predominantly for use as lubricating oil pumps in gears. Special measures prevent the otherwise normally increased noise present in auriferous gear oil. The noise levels do not exceed or only barely exceed the measurements with non-auriferous oils.

Also, there is no noise spectrum shift to higher, unpleasant frequencies. In applications without auriferous portions in the media, it is not recommended to use this version as it will not bring about noise reduction effects there.

The noise optimized version of the KF pump is marked with the special number **197** at the end of the type key. Pumps with the special number **197** are built as pumps in combination with an electric motor or as mounted pumps. The pump in combination with an electric motor (Fig. 1) does not have an outboard bearing, so it has to be driven via an elastic coupling. The mounted pump (Fig. 2) comes equipped with an outboard bearing to absorb the centrifugal forces such as those which arise when using a flying pinion. Pumps for electric motor drives and mounted pumps are sealed at the shaft end using a lip-type shaft seal.

Fig. 1

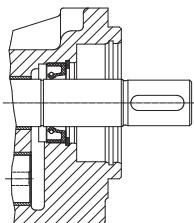
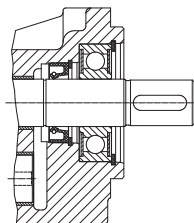

Fig. 2



Pump with single radial lip-type seal

Fixing type: F/W

Sealing materials:

NBR = sealing type 1

FKM = sealing type 2

Special number: 197

Pump with outboard bearing and single radial lip-type seal

Fixing type: G/X

Sealing materials:

NBR = sealing type 1

FKM = sealing type 2

Special number: 197

The noise optimized version is also available in a spheroidal cast iron version. We can supply these pumps in the ATEX version also.

Note

Dimensions conformable standard pumps

Type Key (Ordering example)

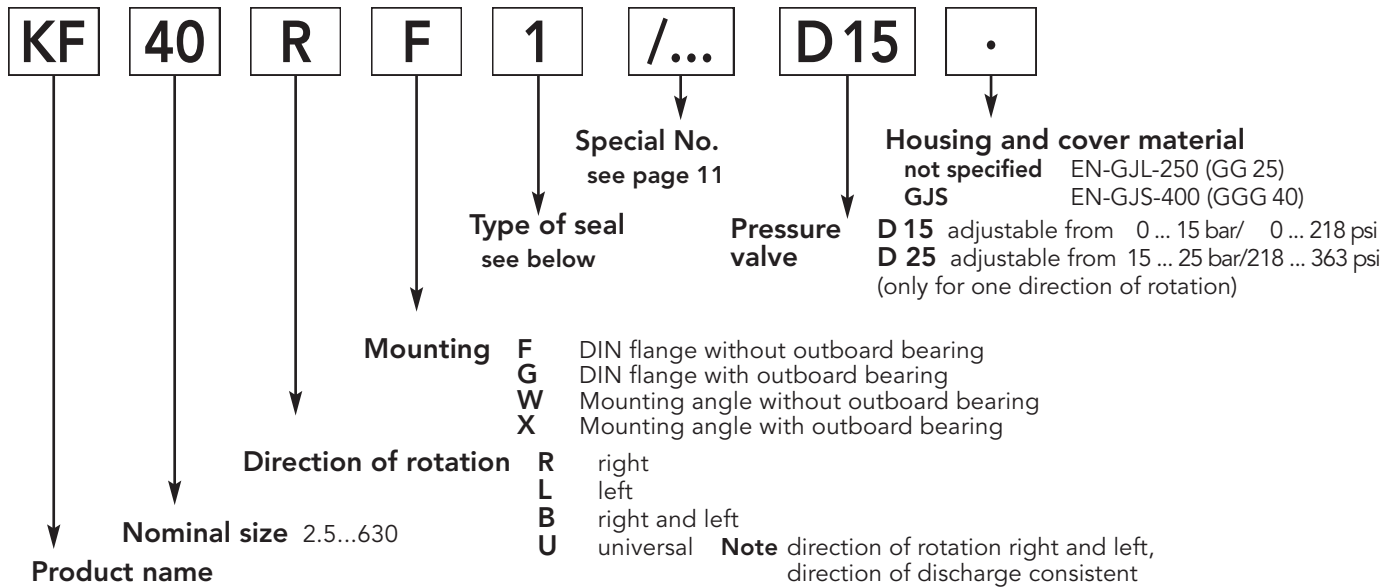

Seal Type

1	Single radial lip-type seal NBR (BABSL)	18	Single radial lip-type seal FKM (BAUMX7)
2	Single radial lip-type seal FKM (BABSL)	19	Double radial lip-type seal NBR (BABSL)
3	Single radial lip-type seal PTFE (HN2390)	23	Single radial lip-type seal FKM (MSS1) (low temperature) (KF 2.5 - 80)
4	Double radial lip-type seal PTFE (HN2390)	30	without shaft seal o-ring FKM
5	Mechanical seal with FKM secondary seals (AX15) C2S2V1G3G1	31	Single radial lip-type seal FKM (BABSL) (low temperature) (KF 32 - 200)
6	Mechanical seal with FFKM secondary seals (AX30) Q2Q2K1G3 (KF 2.5 - 25) Q2B2K1G3 (KF 32 - 200)	32	Double radial lip-type seal EPDM (R02-R) (not resistant to mineral oil)
7	Double radial lip-type seal FKM (BABSL)	36	without shaft seal o-ring NBR
9	Single radial lip-type seal EPDM (R02-R) (not resistant to mineral oil)	40	Mechanical seal with FKM secondary seals (L4) AQ2VFF

Special Numbers

74	Double radial lip-type seal (for vacuum operation) Connection borehole G 1/8" (for Quench)
158	Housing connection: KF 2.5 - 12: Flange connection SAE 3/4" KF 16 - 25: Flange connection SAE 1"
197	Noise-optimized version for aerated oils ⁽¹⁾
198	Mechanical seal with Quench
232	Housing connection: KF 50 - 80: Flange connection SAE 2" KF 100 - 112: Flange connection SAE 2 1/2" KF 125 - 150: Flange connection SAE 3" KF 180 - 200: Flange connection SAE 3 1/2"
277	Vertical mounting position (shaft end above) Separate lubrication for rotating shaft seal (reduced pumping rate) (Size 4: on request)
304	Plastic plain bearings Iglidur® X (non-ferrous metal-free), $\Delta p_{max} = 10 \text{ bar} / 145 \text{ psi}$ (Size 4: on request)
317	Noise-optimized version for aerated oils ⁽¹⁾ (197) Plastic plain bearings Iglidur® X (non-ferrous metal-free), $\Delta p_{max} = 10 \text{ bar} / 145 \text{ psi}$ (304)
322	Triple rotary shaft seal (for normal operation + for vacuum operation) Connection borehole G 1/8" (for Quench) Plastic plain bearings Iglidur® X (non-ferrous metal-free), $\Delta p_{max} = 10 \text{ bar} / 145 \text{ psi}$ (304) Housing connection: KF 32; 40: Flange connection SAE 1 1/2" (Standard) KF 50 - 80: Flange connection SAE 2" (232)
353	Noise-optimized version for aerated oils ⁽¹⁾ (197) Multilayer friction bearings DP4 (lead free) (Size 4: on request)
359	Housing connection: KF 2.5 - 12: Flange connection SAE 3/4" (158) KF 16 - 25: Flange connection SAE 1" (158) Noise-optimized version for aerated oils ⁽¹⁾ (197)
363	Plastic plain bearings Iglidur® X (non-ferrous metal-free), $\Delta p_{max} = 10 \text{ bar} / 145 \text{ psi}$ (304) Housing connection: KF 2.5 - 12: Flange connection SAE 3/4" (158) KF 16 - 25: Flange connection SAE 1" (158)
391	Noise-optimized version for aerated oils ⁽¹⁾ (197) Housing connection: KF 50 - 80: Flange connection SAE 2" (232) KF 100 - 112: Flange connection SAE 2 1/2" (232) KF 125 - 150: Flange connection SAE 3" (232) KF 180 - 200: Flange connection SAE 3 1/2" (232)
402	Double radial lip-type seal (for vacuum operation) (74) Connection borehole G 1/8" (for Quench) (74) Housing connection: KF 2.5 - 12: Flange connection SAE 3/4" (158) KF 16 - 25: Flange connection SAE 1" (158) KF 50 - 80: Flange connection SAE 2" (232) KF 100 - 112: Flange connection SAE 2 1/2" (232) KF 125 - 150: Flange connection SAE 3" (232) KF 180 - 200: Flange connection SAE 3 1/2" (232)
455	Noise-optimized version for aerated oils ⁽¹⁾ (197) Vertical mounting position (shaft end above) Separate lubrication for rotating shaft seal (reduced pumping rate) (277)
459	Double radial lip-type seal (for vacuum operation) (74) Connection borehole G 1/8" (for Quench) (74) Noise-optimized version for aerated oils ⁽¹⁾ (197) Housing connection: KF 2.5 - 12: Flange connection SAE 3/4" (158) KF 16 - 25: Flange connection SAE 1" (158) KF 50 - 80: Flange connection SAE 2" (232) KF 100 - 112: Flange connection SAE 2 1/2" (232) KF 125 - 150: Flanschanschluss SAE 3" (232) KF 180 - 200: Flange connection SAE 3 1/2" (232)

⁽¹⁾ Measures for noise optimisation are only possible for one rotational direction and only effective for aerated oils or vacuum (only in connection with seal versions that are suitable for vacuum operation). Can lead to a reduction of delivery rate.

Technical Data

Nominal size	geom. displacement V_g cm ³ /r	Working pressure * p_b bar / psi	Maximum pressure (pressure-peaks) p_{max} bar / psi	Speed range		Permissible load ** (n = 1500 rpm) F_{radial} N	Sound level dB (A)					
				n_{min} rpm	n_{max} rpm		$p =$ 5 bar/73 psi	$p =$ 15 bar/218 psi	$p =$ 25 bar/363 psi			
2.5	2.55	25 / 363	40 / 580	200	3600	700	65	66	67			
4	4.03											
5	5.05											
6	6.38											
8	8.05											
10	10.11											
12	12.58											
16	16.09											
20	20.1											
25	25.1											
32	32.12											
40	40.21											
50	50.2				3000	40 / 580	200	1500	1500	67	68	68
63	63.18											
80	80.5											
100	101.5											
112	113.5											
125	129.4											
150	155.6	2500	35 / 508	2000	2500	2500	75	75	75			
180	186.6											
200	206.2											
250	245.1	2000	30 / 435	2000	2500	2500	77	77	77			
315	312.9											
400	399.5											
500	496.5											
630	622.5						78	78	80			

Note

* Working pressure p_b = perm. sustained pressure (higher pressures on request)

** Permissible load only for version with outboard bearing. F_{radial} at centre of shaft end.

For certain working conditions, the minimum or maximum characteristics should not be used.

For example, the max. working pressure is not permissible in combination with low speed and low viscosity.

In such limit ranges, please consult us.

Sound level measured in dB(A) at 1 m / 3.3 feet distance

Sound level measured with drive motor, Installation site:

Works hall, quiet sound level = 40 dB(A)

Pump assembly on rigid fastening angle,

Suction and pressure conduits: Hose

measured with gear oil,

Oil viscosity $\nu = 34$ cSt,

Speed $n = 1500$ rpm.

Discharge Flow / Input Power

Speed n = 950 rpm

Discharge Q in l/min - gal/min	Pressure p _b in bar / psi								Nominal size		Pressure p _b in bar / psi					
	2/29	4/58	6/87	8/116	10/145	15/218	20/290	25/363	2/29	4/58	6/87	8/116	10/145	15/218	20/290	25/363
	2.5/0.7	2.4/0.6	2.4/0.6	2.3/0.6	2.2/0.6	2.1/0.6	2.0/0.5	1.8/0.5	2.5	0.03	0.04	0.05	0.06	0.08	0.09	0.11
3.7/1.0	3.7/1.0	3.6/1.0	3.6/1.0	3.6/1.0	3.5/0.9	3.4/0.9	3.3/0.9	4	0.04	0.05	0.07	0.08	0.09	0.13	0.16	0.2
4.6/1.2	4.6/1.2	4.5/1.2	4.5/1.2	4.4/1.2	4.2/1.1	4.1/1.1	3.9/1.0	5	0.04	0.06	0.08	0.1	0.11	0.16	0.2	0.25
5.8/1.5	5.7/1.5	5.6/1.5	5.5/1.5	5.5/1.5	5.3/1.4	5.1/1.3	4.9/1.3	6	0.05	0.07	0.09	0.12	0.14	0.19	0.25	0.3
7.3/1.9	7.3/1.9	7.2/1.9	7.1/1.9	7.0/1.8	6.8/1.8	6.6/1.7	6.4/1.7	8	0.06	0.09	0.11	0.14	0.17	0.24	0.31	0.38
9.2/2.4	9.1/2.4	9.0/2.4	8.9/2.4	8.8/2.3	8.5/2.2	8.2/2.2	7.9/2.1	10	0.07	0.1	0.14	0.17	0.21	0.29	0.38	0.47
11.4/3.0	11.3/3.0	11.2/3.0	11.1/2.9	11.0/2.9	10.8/2.9	10.5/2.8	10.3/2.7	12	0.08	0.12	0.16	0.21	0.25	0.36	0.47	0.58
14.2/3.8	14.0/3.7	13.8/3.6	13.6/3.6	13.4/3.5	12.9/3.4	12.3/3.2	11.8/3.1	16	0.09	0.15	0.2	0.26	0.31	0.45	0.6	0.74
18.0/4.8	17.6/4.6	17.3/4.6	16.9/4.5	16.6/4.4	15.7/4.1	14.9/3.9	14.0/3.7	20	0.1	0.18	0.25	0.32	0.39	0.56	0.74	0.92
22.8/6.0	22.5/5.9	22.3/5.9	22.0/5.8	21.7/5.7	21.1/5.6	20.4/5.4	19.8/5.2	25	0.12	0.21	0.3	0.39	0.48	0.7	0.92	1.14
29.0/7.7	28.0/7.4	27.0/7.1	27.0/7.1	26.0/6.9	25.0/6.6	23.0/6.1	22.0/5.8	32	0.16	0.3	0.4	0.5	0.6	0.9	1.2	1.5
36.0/9.5	36.0/9.5	35.0/9.2	34.0/9.0	34.0/9.0	32.0/8.5	30.0/7.9	28.0/7.4	40	0.25	0.4	0.5	0.6	0.8	1.1	1.5	1.8
45.0/11.9	44.0/11.6	43.0/11.4	42.0/11.1	41.0/10.8	39.0/10.3	36.0/9.5	34.0/9.0	50	0.3	0.5	0.6	0.8	1	1.4	1.9	2.3
57.0/15.1	56.0/14.8	54.0/14.3	53.0/14.0	52.0/13.7	50.0/13.2	46.0/12.2	43.0/11.4	63	0.4	0.6	0.8	1	1.2	1.8	2.4	2.9
74.0/19.6	73.0/19.3	72.0/19.0	71.0/18.8	70.0/18.5	67.0/17.7	65.0/17.2	62.0/16.4	80	0.6	0.8	1.1	1.4	1.6	2.3	3	3.7
92.0/24.3	90.0/23.8	88.0/23.2	86.0/22.7	84.0/22.2	79.0/20.9	73.0/19.3	67.0/17.7	100	0.7	1	1.3	1.6	1.9	2.7	3.6	4.5
102.0/26.9	99.0/26.2	97.0/25.6	94.0/24.8	91.0/24.0	84.0/22.2	77.0/20.3	70.0/18.5	112	0.9	1.2	1.6	2	2.4	3.3	4.3	5.2
114.0/30.1	112.0/29.6	109.0/28.8	106.0/28.0	103.0/27.2	96.0/25.4	89.0/23.5	82.0/21.7	125	1	1.4	1.8	2.3	2.8	3.9	5	6.1
139.0/36.7	137.0/36.2	134.0/35.4	132.0/34.9	129.0/34.1	123.0/32.5	116.0/30.6	110.0/29.1	150	1.1	1.6	2.1	2.6	3.2	4.5	5.8	7.2
169.0/44.6	166.0/43.9	163.0/43.1	160.0/42.3	156.0/41.2	148.0/39.1	140.0/37.0	132.0/34.9	180	1.2	1.8	2.4	3	3.6	5.1	6.6	8.1
187.0/49.4	184.0/48.6	180.0/47.6	177.0/46.8	174.0/46.0	167.0/44.1	159.0/42.0	151.0/39.9	200	1.4	2.1	2.8	3.4	4	5.7	7.3	9
230.0/60.8	226.0/59.7	223.0/58.9	219.0/57.9	216.0/57.1	209.0/55.2	203.0/53.6	197.0/52.0	250	1.5	2.3	3.1	4	4.8	6.8	8.9	10.9
295.0/77.9	290.0/76.6	286.0/75.6	282.0/74.5	279.0/73.7	272.0/71.9	265.0/70.0	259.0/68.4	315	2	3	4	5.1	6.1	8.7	11.2	13.8
376.0/99.3	369.0/97.5	363.0/95.9	358.0/94.6	353.0/93.3	341.0/90.1	330.0/87.2	320.0/84.5	400	2.6	3.8	5.1	6.4	7.7	11	14.3	17.5
467.0/123.4	461.0/121.8	454.0/119.9	449.0/118.6	443.0/117.0	430.0/113.6	418.0/110.4	407.0/107.5	500	3.3	4.9	6.5	8.1	9.8	13.9	18	22.1
587.0/155.1	578.0/152.7	570.0/150.6	562.0/148.5	554.0/146.4	537.0/141.9	523.0/138.2	511.0/135.0	630	4.5	6.6	8.7	10.7	12.8	18.1	23.3	28.6

Power consumption P in KW

Speed n = 1450 rpm

Discharge Q in l/min - gal/min	Pressure p _b in bar / psi								Nominal size		Pressure p _b in bar / psi					
	2/29	4/58	6/87	8/116	10/145	15/218	20/290	25/363	2/29	4/58	6/87	8/116	10/145	15/218	20/290	25/363
	3.6/1.0	3.6/1.0	3.5/0.9	3.5/0.9	3.5/0.9	3.4/0.9	3.3/0.9	3.2/0.8	2.5	0.04	0.05	0.08	0.1	0.12	0.14	0.16
5.7/1.5	5.7/1.5	5.6/1.5	5.6/1.5	5.5/1.5	5.4/1.4	5.4/1.4	5.3/1.4	4	0.06	0.08	0.1	0.12	0.15	0.2	0.25	0.3
6.9/1.8	6.8/1.8	6.8/1.8	6.7/1.8	6.7/1.8	6.6/1.7	6.5/1.7	6.4/1.7	5	0.07	0.1	0.12	0.15	0.19	0.27	0.35	0.43
8.9/2.4	8.8/2.3	8.8/2.3	8.7/2.3	8.6/2.3	8.4/2.2	8.2/2.2	8.0/2.1	6	0.08	0.11	0.15	0.18	0.22	0.32	0.39	0.47
11.3/3.0	11.2/3.0	11.1/2.9	11.0/2.9	10.9/2.9	10.8/2.9	10.6/2.8	10.4/2.7	8	0.09	0.14	0.18	0.21	0.27	0.37	0.47	0.58
14.2/3.8	14.1/3.7	14.1/3.7	13.8/3.6	13.7/3.6	13.4/3.5	13.1/3.5	12.8/3.4	10	0.11	0.16	0.21	0.27	0.32	0.45	0.58	0.72
17.6/4.6	17.5/4.6	17.4/4.6	17.3/4.6	17.2/4.5	16.9/4.5	16.7/4.4	16.5/4.4	12	0.12	0.19	0.26	0.32	0.39	0.55	0.72	0.89
22.2/5.9	21.9/5.8	21.7/5.7	21.4/5.7	21.2/5.6	20.5/5.4	19.9/5.3	19.3/5.1	16	0.16	0.26	0.37	0.47	0.57	0.82	1.08	1.33
27.9/7.4	27.5/7.3	27.1/7.2	26.8/7.1	26.4/7.0	25.5/6.7	24.5/6.5	23.6/6.2	20	0.17	0.28	0.39	0.49	0.6	0.87	1.14	1.41
35.3/9.3	35.0/9.2	34.7/9.2	34.4/9.1	34.1/9.0	33.3/8.8	32.6/8.6	31.8/8.4	25	0.24	0.34	0.47	0.61	0.74	1.08	1.41	1.75
45.0/11.9	44.0/11.6	43.0/11.4	43.0/11.4	42.0/11.1	41.0/10.8	39.0/10.3	37.0/9.8	32	0.3	0.5	0.7	0.8	1	1.4	1.9	2.3
57.0/15.1	56.0/14.8	55.0/14.5	55.0/14.5	54.0/14.3	52.0/13.7	50.0/13.2	48.0/12.7	40	0.4	0.6	0.9	1.1	1.3	1.8	2.3	2.9
70.0/18.5	69.0/18.2	68.0/18.0	67.0/17.7	66.0/17.4	64.0/16.9	61.0/16.1	58.0/15.3	50	0.5	0.8	1.1	1.3	1.6	2.3	2.9	3.6
88.0/23.2	87.0/23.0	86.0/22.7	85.0/22.5	84.0/22.2	81.0/21.4	78.0/20.6	75.0/19.8	63	0.7	1	1.3	1.7	2	2.9	3.7	4.5
114.0/30.1	113.0/29.9	112.0/29.6	111.0/29.3	110.0/29.1	107.0/28.3	105.0/27.7	103.0/27.2	80	0.9	1.4	1.8	2.2	2.6	3.6	4.6	5.7
144.0/38.0	142.0/37.5	140.0/37.0	138.0/36.5	137.0/36.2	131.0/34.6	128.0/33.8	126.0/33.3	100	1.2	1.6	2	2.5	3	4.3	5.7	7
161.0/42.5	159.0/42.0	157.0/41.5	154.0/40.7	152.0/40.2	147.0/38.8	142.0/37.5	138.0/36.5	112	1.4	2	2.6	3.1	3.7	5.2	6.7	8.2
181.0/47.8	178.0/47.0	175.0/46.2	172.0/45.4	169.0/44.6	162.0/42.8	155.0/41.0	147.0/38.8	125	1.7	2.3	2.9	3.6	4.2	5.8	7.4	9
218.0/57.6	216.0/57.1	213.0/56.3	211.0/55.7	209.0/55.2	203.0/53.6	197.0/52.0	191.0/50.5	150	2	2.7	3.5	4.2	5	6.9	8.9	11
264.0/69.7	261.0/69.0	257.0/67.9	254.0/67.1	251.0/66.3	242.0/63.9	234.0/61.8	226.0/59.7	180	2.3	3.2	4.1	5	5.9	8.2	10.4	12.7
293.0/77.4	290.0/76.6	287.0/75.8	283.0/74.8	280.0/74.0	272.0/71.9	264.0/69.7	256.0/67.6	200	2.6	3.6	4.6	5.6	6.6	9.1	11.6	14
356.0/94.1	352.0/93.0	348.0/91.9	344.0/90.9	341.0/90.1	334.0/88.2	327.0/86.4	321.0/84.8	250	3.1	4.3	5.6	6.8	8.1	11.2	14.3	17.4
455.0/120.2	450.0/118.9	446.0/117.8	442.0/116.8	439.0/116.0	431.0/113.9	424.0/112.0	418.0/110.4	315	4.1	5.7	7.2	8.8	10.4	14.3	18.3	22.2
579.0/153.0	573.0/151.4	567.0/149.8	562.0/148.5	557.0/147.2	545.0/144.0	535.0/141.3	524.0/138.4	400	5.6	7.5	9.5	11.5	13.5	18.4	23.4	28.5
719.0/190.0	712.0/188.1	707.0/186.8	701.0/185.2	696.0/183.9	684.0/180.7	673.0/177.8	662.0/174.9	500	7.4	9.8	12.2	14.7	17.2	23.4	29.7	36.1
902.0/238.3	894.0/236.2	887.0/234.3	880.0/232.5	874.0/230.9	858.0/226.7	845.0/223.2	834.0/220.3	630	10.1	13.2	16.4	19.6	22.9	31	39.1	47.4

Power consumption P in KW

Discharge Flow / Input Power

Speed n = 1150 rpm

Discharge Q in l/min - gal/min	Pressure p _b in bar / psi						Nominal size		Pressure p _b in bar / psi							
	2/29	4/58	6/87	8/116	10/145	15/218	20/290	25/363	2/29	4/58	6/87	8/116	10/145	15/218	20/290	25/363
	2.9/0.8	2.9/0.8	2.8/0.7	2.8/0.7	2.7/0.7	2.6/0.7	2.5/0.7	2.4/0.6	2.5	0.03	0.04	0.06	0.08	0.1	0.11	0.13
4.5/1.2	4.5/1.2	4.4/1.2	4.4/1.2	4.4/1.2	4.3/1.1	4.2/1.1	4.1/1.1	4	0.05	0.06	0.08	0.1	0.11	0.16	0.2	0.24
5.5/1.5	5.5/1.5	5.4/1.4	5.4/1.4	5.3/1.4	5.2/1.4	5.1/1.3	4.9/1.3	5	0.05	0.08	0.1	0.12	0.14	0.2	0.26	0.32
7.0/1.8	6.9/1.8	6.9/1.8	6.8/1.8	6.7/1.8	6.5/1.7	6.3/1.7	6.1/1.6	6	0.06	0.09	0.11	0.14	0.17	0.24	0.31	0.37
8.9/2.4	8.9/2.4	8.8/2.3	8.7/2.3	8.6/2.3	8.4/2.2	8.2/2.2	8.0/2.1	8	0.07	0.11	0.14	0.17	0.21	0.29	0.37	0.46
11.2/3.0	11.1/2.9	11.0/2.9	10.9/2.9	10.8/2.9	10.5/2.8	10.2/2.7	9.9/2.6	10	0.09	0.12	0.17	0.21	0.25	0.35	0.46	0.57
13.9/3.7	13.8/3.6	13.7/3.6	13.6/3.6	13.5/3.6	13.2/3.5	13.0/3.4	12.8/3.4	12	0.1	0.15	0.2	0.25	0.31	0.44	0.57	0.7
17.4/4.6	17.2/4.5	17.0/4.5	16.7/4.4	16.5/4.4	15.9/4.2	15.3/4.0	14.8/3.9	16	0.12	0.19	0.27	0.34	0.41	0.6	0.79	0.98
22.0/5.8	21.6/5.7	21.2/5.6	20.9/5.5	20.5/5.4	19.6/5.2	18.7/4.9	17.8/4.7	20	0.13	0.22	0.31	0.39	0.47	0.68	0.9	1.12
27.8/7.3	27.5/7.3	27.3/7.2	27.0/7.1	26.7/7.1	26.0/6.9	25.3/6.7	24.6/6.5	25	0.17	0.26	0.37	0.48	0.58	0.85	1.12	1.38
35.0/9.2	34.0/9.0	33.0/8.7	33.0/8.7	32.0/8.5	31.0/8.2	29.0/7.7	28.0/7.4	32	0.2	0.4	0.5	0.6	0.8	1.1	1.5	1.8
44.0/11.6	44.0/11.6	43.0/11.4	42.0/11.1	42.0/11.1	40.0/10.6	38.0/10.0	36.0/9.5	40	0.3	0.5	0.7	0.8	1.0	1.4	1.8	2.2
55.0/14.5	54.0/14.3	53.0/14.0	52.0/13.7	51.0/13.5	49.0/12.9	46.0/12.2	44.0/11.6	50	0.4	0.6	0.8	1	1.2	1.8	2.3	2.8
69.0/18.2	68.0/18.0	67.0/17.7	66.0/17.4	65.0/17.2	62.0/16.4	59.0/15.6	56.0/14.8	63	0.5	0.8	1	1.3	1.5	2.2	2.9	3.5
90.0/23.8	89.0/23.5	88.0/23.2	87.0/23.0	86.0/22.7	83.0/21.9	81.0/21.4	79.0/20.9	80	0.7	1	1.4	1.7	2	2.8	3.6	4.5
113.0/29.9	111.0/29.3	109.0/28.8	107.0/28.3	105.0/27.7	100.0/26.4	95.0/25.1	91.0/24.0	100	0.9	1.2	1.6	2	2.3	3.3	4.4	5.5
126.0/33.3	123.0/32.5	121.0/32.0	118.0/31.2	115.0/30.4	109.0/28.8	103.0/27.2	97.0/25.6	112	1.1	1.5	2	2.4	2.9	4.1	5.3	6.4
141.0/37.3	138.0/36.5	135.0/35.7	132.0/34.9	129.0/34.1	122.0/32.2	115.0/30.4	108.0/28.5	125	1.3	1.8	2.2	2.8	3.4	4.7	6	7.3
171.0/45.2	169.0/44.6	166.0/43.9	164.0/43.3	161.0/42.5	155.0/41.0	148.0/39.1	142.0/37.5	150	1.5	2	2.7	3.2	3.9	5.5	7	8.7
207.0/54.7	204.0/53.9	201.0/53.1	198.0/52.3	194.0/51.3	186.0/49.1	178.0/47.0	170.0/44.9	180	1.6	2.4	3.1	3.8	4.5	6.3	8.1	9.9
229.0/60.5	226.0/59.7	229.0/60.5	219.0/57.9	216.0/57.1	209.0/55.2	201.0/53.1	193.0/51.0	200	1.9	2.7	3.5	4.3	5	7.1	9	11
280.0/74.0	276.0/72.9	273.0/72.1	269.0/71.1	266.0/70.3	259.0/68.4	253.0/66.8	247.0/65.3	250	2.1	3.1	4.1	5.1	6.1	8.6	11.1	13.5
359.0/94.8	354.0/93.5	350.0/92.5	346.0/91.4	343.0/90.6	336.0/88.8	329.0/86.9	323.0/85.3	315	2.8	4.1	5.3	6.6	7.8	10.9	14	17.2
457.0/120.7	451.0/119.2	445.0/117.6	440.0/116.2	435.0/114.9	423.0/111.8	412.0/108.9	402.0/106.2	400	3.8	5.3	6.9	8.4	10	14	17.9	21.9
568.0/150.1	561.0/148.2	555.0/146.6	550.0/145.3	544.0/143.7	532.0/140.6	520.0/137.4	509.0/134.5	500	4.9	6.9	8.8	10.7	12.8	17.7	22.7	27.7
713.0/188.4	704.0/186.0	697.0/184.1	689.0/182.0	682.0/180.2	665.0/175.7	652.0/172.3	640.0/169.1	630	6.7	9.2	11.8	14.3	16.8	23.3	29.6	36.1

Power consumption P in KW

Speed n = 1750 rpm

Discharge Q in l/min - gal/min	Pressure p _b in bar / psi						Nominal size		Pressure p _b in bar / psi							
	2/29	4/58	6/87	8/116	10/145	15/218	20/290	25/363	2/29	4/58	6/87	8/116	10/145	15/218	20/290	25/363
	4.3/1.1	4.3/1.1	4.2/1.1	4.2/1.1	4.3/1.1	4.2/1.1	4.1/1.1	4.0/1.1	2.5	0.05	0.06	0.1	0.12	0.14	0.17	0.19
6.9/1.8	6.9/1.8	6.8/1.8	6.8/1.8	6.6/1.7	6.5/1.7	6.6/1.7	6.5/1.7	4	0.07	0.1	0.12	0.14	0.19	0.24	0.3	0.36
8.3/2.2	8.1/2.1	8.2/2.2	8.0/2.1	8.1/2.1	8.0/2.1	7.9/2.1	7.9/2.1	5	0.09	0.12	0.14	0.18	0.24	0.34	0.44	0.54
10.8/2.9	10.7/2.8	10.7/2.8	10.6/2.8	10.5/2.8	10.3/2.7	10.1/2.7	9.9/2.6	6	0.1	0.13	0.19	0.22	0.27	0.4	0.47	0.57
13.7/3.6	13.5/3.6	13.4/3.5	13.3/3.5	13.2/3.5	13.2/3.5	13.0/3.4	12.8/3.4	8	0.11	0.17	0.22	0.27	0.31	0.45	0.57	0.70
17.2/4.5	17.1/4.5	17.2/4.5	16.7/4.4	16.6/4.4	16.3/4.3	16.0/4.2	15.7/4.1	10	0.13	0.20	0.25	0.33	0.39	0.55	0.7	0.87
21.3/5.6	21.2/5.6	21.1/5.6	21.0/5.5	20.9/5.5	20.6/5.4	20.4/5.4	20.2/5.3	12	0.14	0.23	0.32	0.39	0.47	0.66	0.87	1.08
27.0/7.1	26.6/7.0	26.4/7.0	26.1/6.9	25.9/6.8	25.1/6.6	24.5/6.5	23.8/6.3	16	0.2	0.33	0.47	0.60	0.73	1.04	1.37	1.68
33.8/8.9	33.4/8.8	33.0/8.7	32.7/8.6	32.3/8.5	31.4/8.3	30.3/8.0	29.4/7.8	20	0.21	0.34	0.47	0.59	0.73	1.06	1.38	1.7
42.8/11.3	42.5/11.2	42.1/11.1	41.8/11.0	41.5/11.0	40.6/10.7	39.9/10.5	39.0/10.3	25	0.31	0.42	0.57	0.74	0.90	1.31	1.7	2.12
55.0/14.5	54.0/14.3	53.0/14.0	53.0/14.0	52.0/13.7	51.0/13.5	49.0/12.9	46.0/12.2	32	0.4	0.6	0.9	1	1.2	1.7	2.3	2.8
70.0/18.5	68.0/18.0	67.0/17.7	68.0/18.0	66.0/17.4	64.0/16.9	62.0/16.4	60.0/15.9	40	0.5	0.7	1.1	1.4	1.6	2.2	2.8	3.6
85.0/22.5	84.0/22.2	83.0/21.9	82.0/21.7	81.0/21.4	79.0/20.9	76.0/20.1	72.0/19.0	50	0.6	1	1.4	1.6	2	2.8	3.5	4.4
107.0/28.3	106.0/28.0	105.0/27.7	104.0/27.5	103.0/27.2	100.0/26.4	97.0/25.6	94.0/24.8	63	0.9	1.2	1.6	2.1	2.5	3.6	4.5	5.5
138.0/36.5	137.0/36.2	136.0/35.9	135.0/35.7	134.0/35.4	131.0/34.6	129.0/34.1	127.0/33.6	80	1.1	1.7	2.2	2.7	3.2	4.4	5.6	6.9
175.0/46.2	173.0/45.7	171.0/45.2	169.0/44.6	169.0/44.6	162.0/42.8	162.0/42.8	161.0/42.5	100	1.5	2	2.4	3	3.7	5.3	7	8.5
196.0/51.8	195.0/51.5	193.0/51.0	190.0/50.2	189.0/49.9	185.0/48.9	181.0/47.8	179.0/47.3	112	1.7	2.5	3.2	3.8	4.5	6.3	8.1	10
221.0/58.4	218.0/57.6	215.0/56.8	212.0/56.0	209.0/55.2	202.0/53.4	195.0/51.5	186.0/49.1	125	2.1	2.8	3.6	4.4	5	6.9	8.8	10.7
265.0/70.0	263.0/69.5	260.0/68.7	258.0/68.2	257.0/67.9	251.0/66.3	246.0/65.0	240.0/63.4	150	2.5	3.4	4.3	5.2	6.1	8.3	10.8	13.3
321.0/84.8	318.0/84.0	313.0/82.7	310.0/81.9	308.0/81.4	298.0/78.7	290.0/76.6	282.0/74.5	180	3	4	5.1	6.2	7.3	10.1	12.7	15.5
357.0/94.3	354.0/93.5	351.0/92.7	347.0/91.7	344.0/90.9	335.0/88.5	327.0/86.4	319.0/84.3	200	3.3	4.5	5.7	6.9	8.2	11.1	14.2	17
432.0/114.1	428.0/113.1	423.0/111.8	419.0/110.7	416.0/109.9	409.0/108.1	401.0/105.9	395.0/104.4	250	4.1	5.5	7.1	8.5	10.1	13.8	17.5	21.3
551.0/145.6	546.0/144.3	542.0/143.2	538.0/142.1	535.0/141.3	526.0/139.0	519.0/137.1	513.0/135.5	315	5.4	7.3	9.1	11	13	17.7	22.6	27.2
701.0/185.2	695.0/183.6	689.0/182.0	684.0/180.7	679.0/179.4	667.0/176.2	658.0/173.8	646.0/170.7	400	7.4	9.7	12.1	14.6	17	22.8	28.9	31.5
870.0/229.9	863.0/228.0	859.0/226.9	852.0/225.1	848.0/224.0	836.0/220.9	826.0/218.2	815.0/215.3	500	9.9	12.7	15.6	18.7	21.6	29.1	36.7	44.5
1091.0/288.2	1084.0/286.4	1077.0/284.5	1071.0/283.0	1066.0/281.6	1051.0/277.7	1038.0/274.2	1028.0/271.6	630	13.5	17.2	21	24.9	29	38.7	48.6	58.7

Power consumption P in KW

Discharge Flow/ Input Power

Notes:

- The ratings refer to a mineral oil with a viscosity of 34 cSt
- Margin of error for the flow Q + 2.5% ... - 5% of the tabular value.
- For viscosity < 30 cSt, take a reduction of the rated flow Q into account.
- The output of the drive motor should be selected 20% higher than tabular value P.
- For viscosity > 100 cSt, an increase in the required power is necessary, in this case proceed as per description on this page.
- -3% of discharge flow for the noise-optimized version.

Calculation of input power

Calculation

$$P_{1Pu} = P_{tab} \cdot \frac{n}{1450} + f_v \cdot Q$$

P_{1Pu} = pump power consumption (kW)

P_{tab} = power consumption per table (kW) at 1450 [rpm]

n = speed [rpm]
dependent on viscosity!
(see speed recommendation)

f_v = viscosity factor $\left[\frac{\text{kW}}{\text{l/min} - \text{gal/min}} \right]$
(see diagram)

Q = discharge flow (l/min - gal/min) with $= \frac{V_g \cdot n}{1000}$

V_g = geometrical displacement (cm³/r)

Conversion factors

$$1 \text{ bar} \triangleq 14.5 \frac{\text{lb}}{\text{in}^2} = 14.5 \text{ psi}$$

$$1 \frac{\text{l}}{\text{min}} \triangleq 0.220 \frac{\text{gal}}{\text{min}} = [\text{U.K.}]$$

Example: Pump type KF 80

Viscosity $v = 3000 \text{ cSt}$

Working pressure $p = 15 \text{ bar} / 218 \text{ psi}$

at $P_{tab} = 3.6 \text{ kW}$

$n = 500 \text{ rpm}$

$f_v = 0.017 \frac{\text{kW}}{\text{l/min} - \text{gal/min}}$

$$Q = \frac{80,5 \cdot 500}{1000} = 40 \text{ l/min} - 10.6 \text{ gal/min}$$

becomes

$$P_{1Pu} = \left(3.6 \cdot \frac{500}{1450} + 0.017 \cdot 40 \right) \text{ kW}$$

$P_{1Pu} = 1.92 \text{ kW}$

Motorpower

output:

$$P_{2Mot} = 1.2 \cdot P_{1Pu} = 2.3 \text{ kW}$$

Select helical

geared motor with

$P = 3.0 \text{ kW}$

$n = 500 \text{ rpm}$

$$1 \frac{\text{l}}{\text{min}} \triangleq 0,264 \frac{\text{gal}}{\text{min}} = [\text{US}]$$

Input Power



Diagramm: $n, f_v = f(v)$

Note:

To determine the power consumption, always take the max. working viscosity at starting state into consideration.

The power of the drive motor should be selected 20% higher than the value determined.

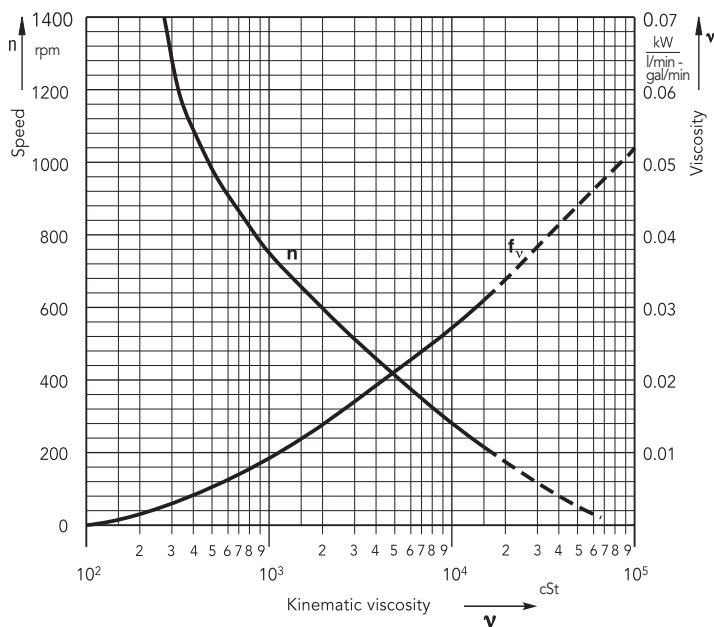
Flange-Mounting Version with Pipe Thread

KF 2.5...25

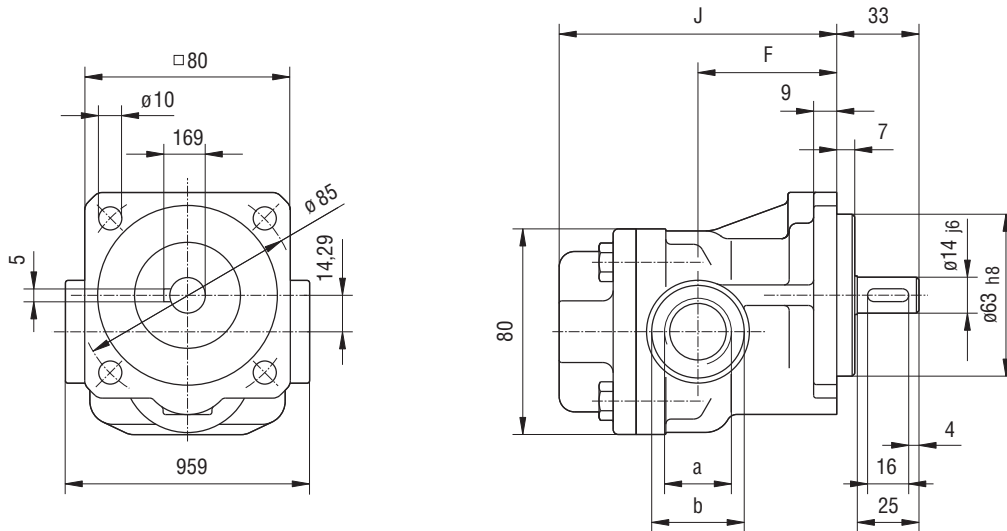

KF 2.5...25 with pressure relief valve

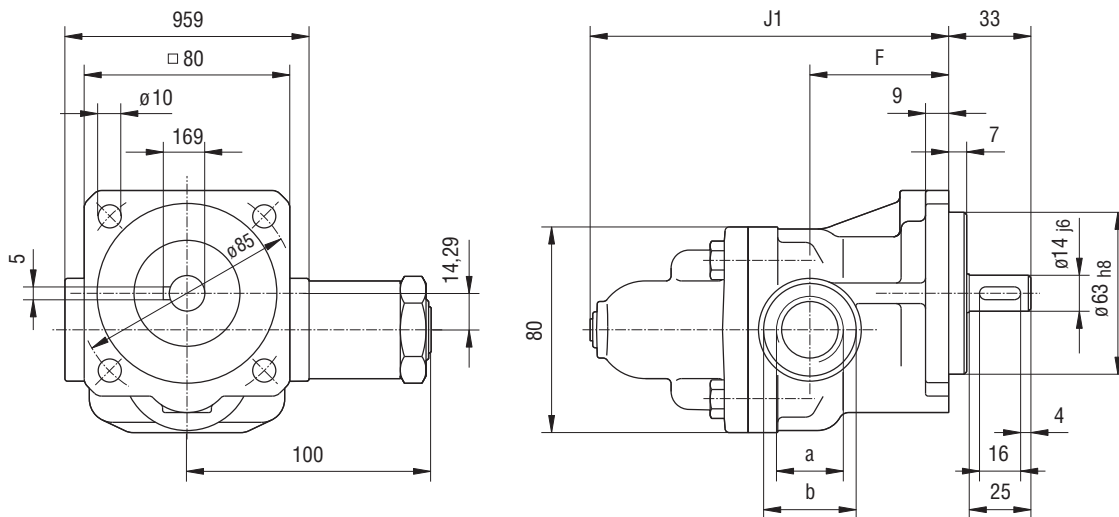

Nominal size	Suction and pressure connection		F	J	J ₁	Weight in kg/lbs	
	a	b				without valve	with valve
2.5...12	G 3/4 17 deep	Ø 36	54	108	140	2.9/6.4	3.7/8.2
16...25	G 1 19 deep	Ø 42	63	130	162	3.5/7.7	4.3/9.5

(Dimensions in mm)

Flange-Mounting Version with SAE-Connection

KF 2.5...630

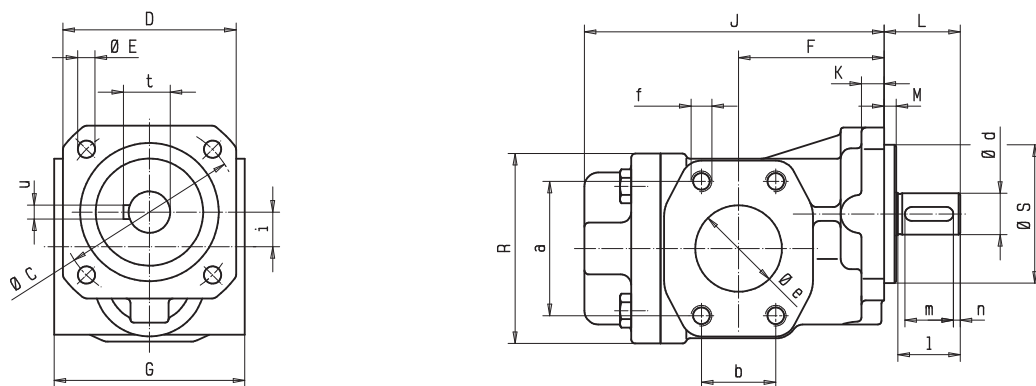

KF 2.5...630 with pressure relief valve

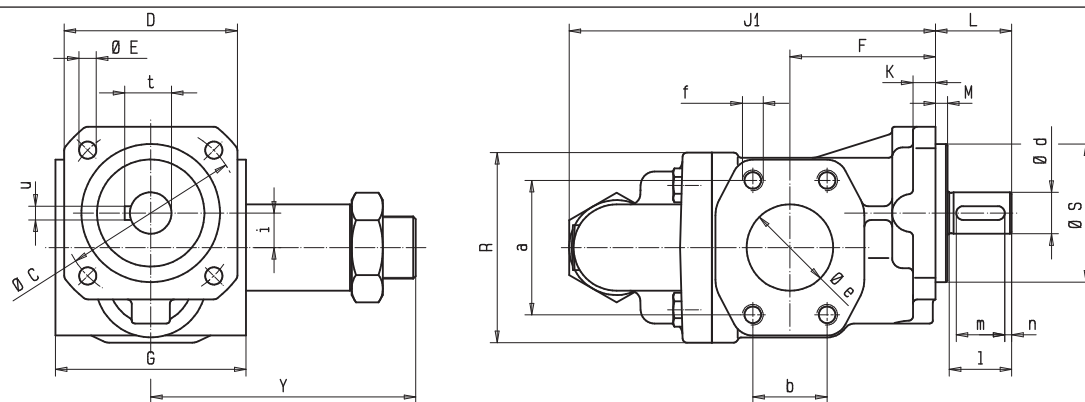

Nominal size	Sp.-No.	SAE	Seal	Suction- and pressure connection				Dimensions gear pump														Shaft end					Weight in kg/lbs																														
				a	b	e	f	C	D	E	F	G	J	J ₁	K	L	M	R	S _{h8}	i	Y	d _{j6}	l	m	n	t	u	without valve	with valve																												
2.5...12	158	3/4"	-	47.6	22.2	19.5	M10-15 deep	85	80	10	54	108	140	9	33	7	80	63	14.2	99.5	14	25	16	4	16	5	4.2/9.3	5.0/11.0																													
16...25	158	1"	-	52.4	26.2	25.0	M10-17 deep				63	130	162														4.8/10.6	5.6/12.3																													
32...50	-	1 1/2"	-	69.9	35.7	38.0	M12-20 deep	103	100	10	84	172	211.5	13	44	7	110	80	20	150.5	24	36	28	4	27	8	7.7/17.0	9.5/20.9																													
63/80	-	1 1/2"	-			100					110	207	246.5																																												
50	232	2"	-			84						172	211.5																																												
63/80	232	2"	-	77.8	42.9	50.0																						100	207	246.5																											
100/112	-	2"	-	88.9	50.8	63.5	M16-32 deep	145	135	14	120	245	282	18	46	159	110	23.7	170.5	28	50	40	5	31	8	16/35.3	18.7/41.2																														
100/112	-	2"	31																																																						
100/112	232	2 1/2"	-																														102	130	220.5	262.5	17																				
100/112	232	2 1/2"	31																																																						
125/150	-	2 1/2"	-	106.4	61.9	76.2	M16-32 deep	145	135	14	120	245	282	18	46	159	110	23.7	170.5	28	50	40	5	31	8	22.2/48.9	24.9/54.9																														
125/150	-	2 1/2"	31																																																						
125/150	232	3"	-																																																						
125/150	232	3"	31																																																						
180/200	-	3"	-	120.7	69.9	88.9	M16-32 deep	145	135	14	120	245	282	18	46	159	110	23.7	170.5	28	50	40	5	31	8	24.8/54.7	27.5/60.6																														
180/200	-	3"	31																																																						
180/200	232	3 1/2"	-																																																						
180/200	232	3 1/2"	31																																																						
250/315	-	3"	-	106.4	61.9	76.2	M16-32 deep	200	185	19	155	200	311	364	26	90	8	208	160	35.5	240	38	80	63	8	41	10	44.2/97.4	47.6/104.9																												
400/500	-	4"	-																																																						
630	-	4"	-	130.2	77.8	101.6					200		417	470														60.8/134.0	64.2/141.5																												

Weight with mounting angel: KF 2.5...25 plus 1.3 kg / 2.9 lbs, KF 32...80 plus 1.8 kg / 4.0 lbs.

Pump with Mounting Angle, Pipe Thread

KF 2.5...25

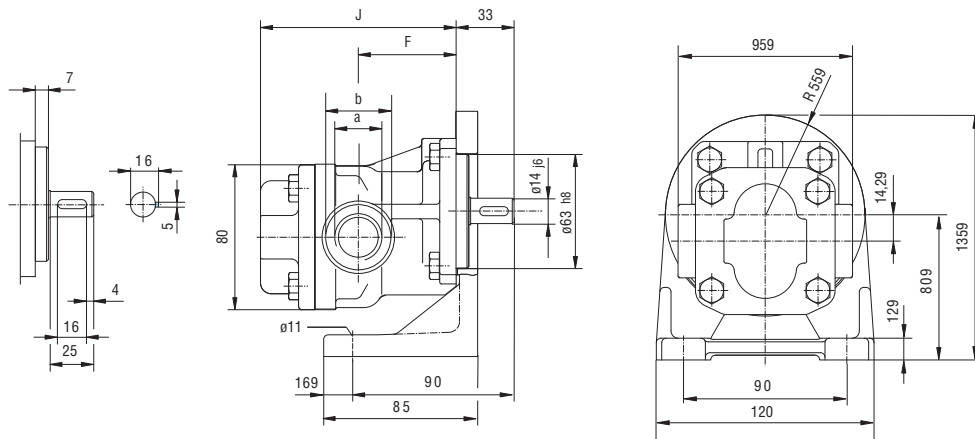

Nominal size	Suction and pressure connection		F	J	Weight in kg / lbs
	a	b			
2.5...12	G 3/4 17 deep	Ø 36	54	108	4.2/ 9.3
16...25	G 1 19 deep	Ø 42	63	130	4.8/10.6

(Dimensions in mm)

Pump with Mounting Angle, Pipe Thread, SAE 1 1/2-connection

KF 32...80

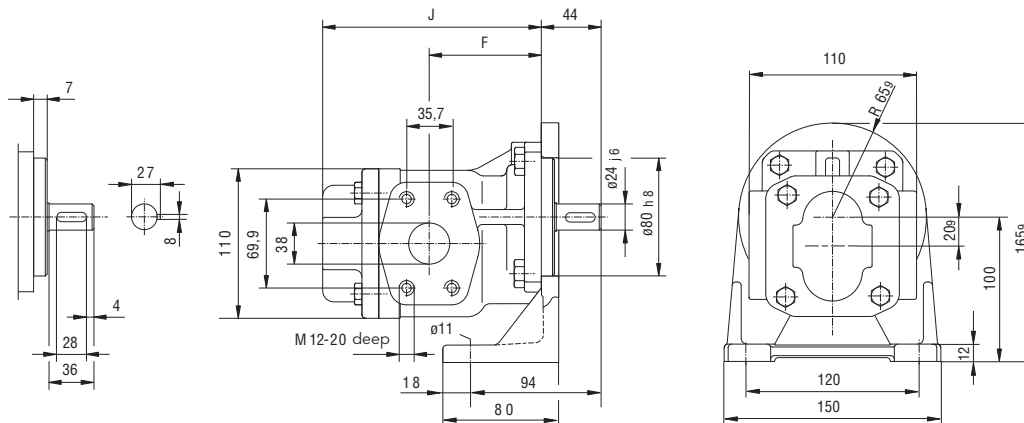

Nominal size		F	J	Weight in kg / lbs
32...50	SAE 1 1/2	84	172	9.5/20.9
63/80	SAE 1 1/2	100	207	11.2/24.7

(Dimensions in mm)

Flange-Mounting Version with Universal Valve U2

KF 32...80

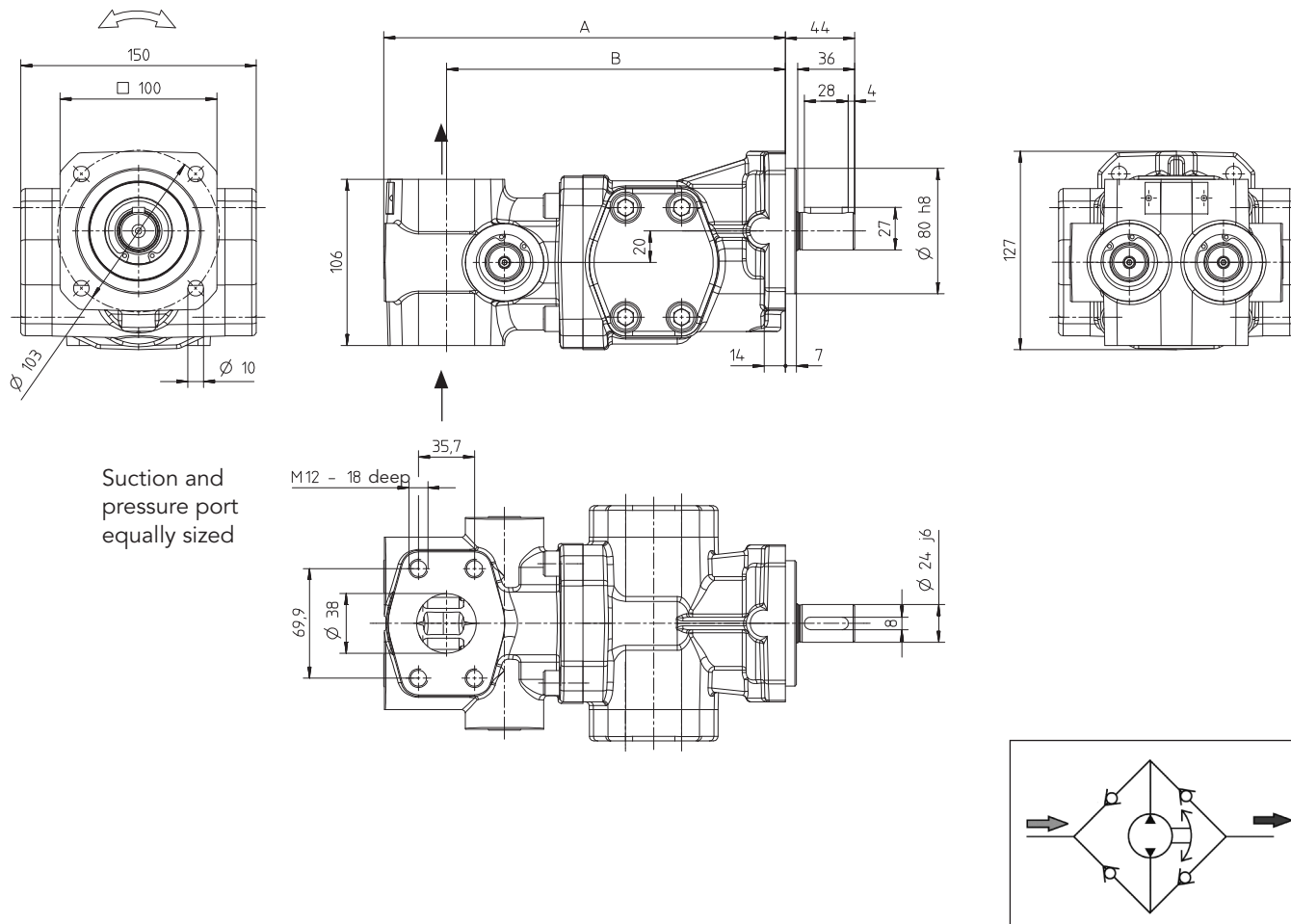

Nominal size	A	B	Weight in kg / lbs
32			
40	256	216	15.5/34.2
50			
63	291	251	17.5/38.6
80			

(Dimensions in mm)

Mounting position optional

Flange-Mounting Version with Universal Valve U2

KF 100/112

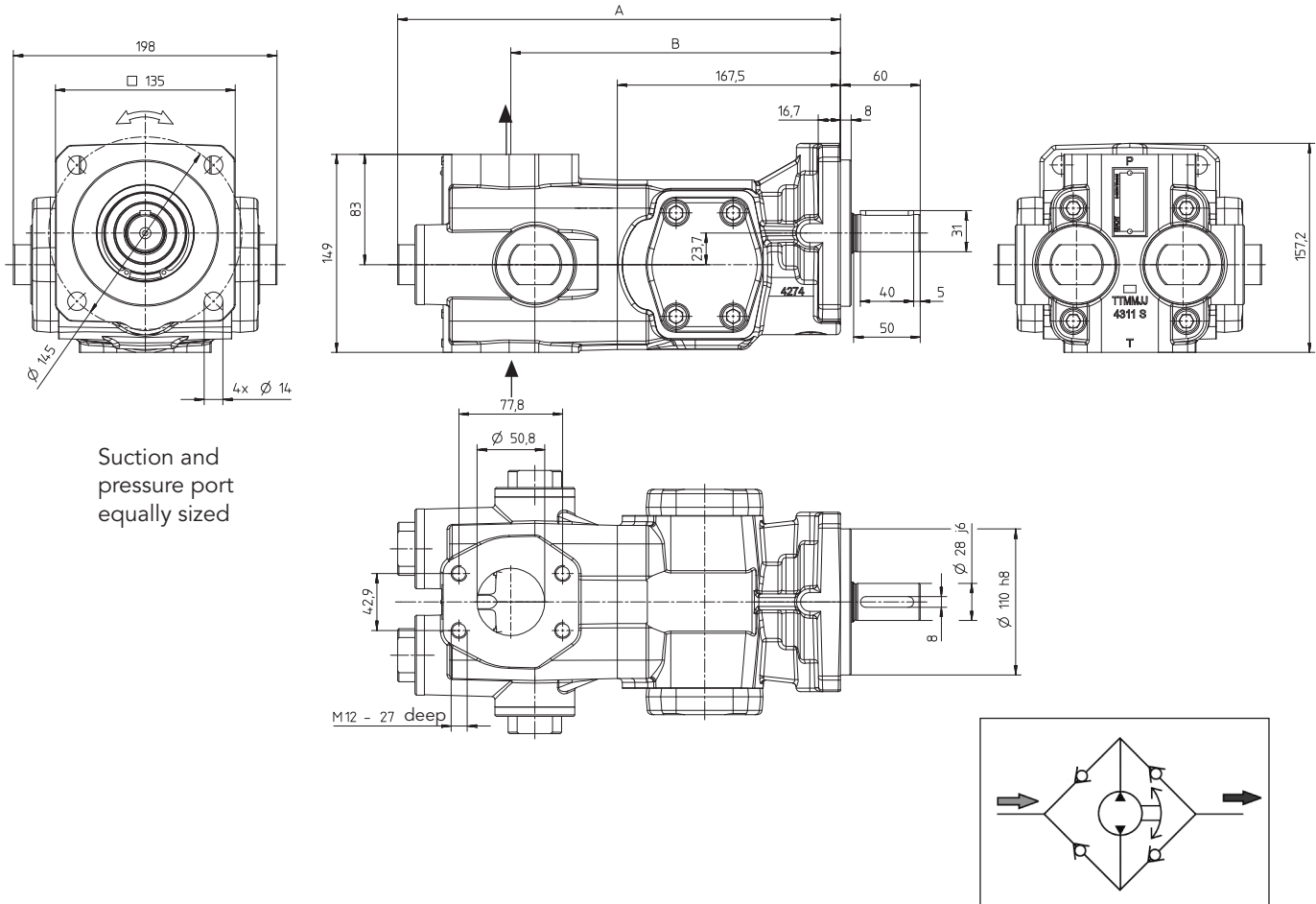

Nominal size	A	B	Weight in kg / lbs
100 112	312.5	247.5	21.6/47.6

(Dimensions in mm)

Mounting position optional

Accessory Bell Housing and Couplings

KF 2.5...630 Aluminum bell housing

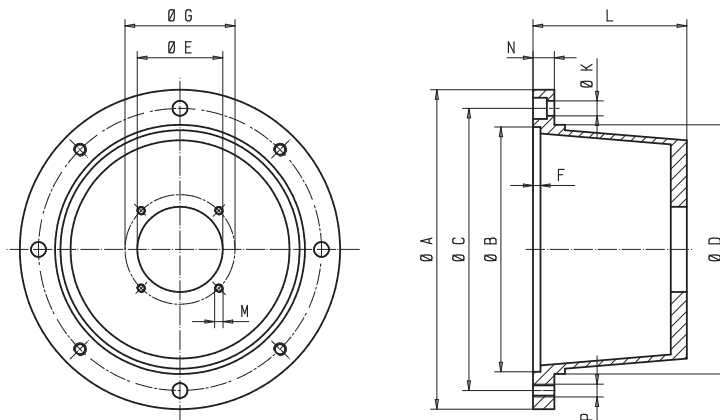

	Motor size	Bell housing	Coupling	Dimensions (in mm)											Weight [kg/lbs]	
				A	B	C	D	E	F	G	K	L	M	N		P
KF 2.5...25	71	PT 160-A-063-80	RA 19-Z25/14-Z25/14	160	110	130	110	63	7	85	9	80	M8	13	M8	0.5/1.1
	80	PT 200-A-063-100	RA 19-Z25/14-Z25/19	200	130	165	145				11	100		16	M10	0.7/1.5
	90	PT 200-A-063-100	RA 19/24-Z25/14-Z25/24	200	130	165	145				11	100		16	M10	0.7/1.5
	100/112	PT 250-A-063-120	RA 24/28-Z30/14-Z30/28	250	180	215	190				14	120		19	M12	1.3/2.9
KF 32...80	80	PT 200-A-080-100	RA 19/24-Z25/24-Z25/19	200	130	165	145	80	7	103	11	100	M8	16	M10	0.9/2.0
	90	PT 200-A-080-110	RA 24-Z30/24-Z30/24								11	110				18
	100/112	PT 250-A-080-124	RA 24/28-Z30/24-Z30/28	250	180	215	190				14	124		20	M12	1.0/2.2
	132	PT 300-A-080-144	RA 28/38-Z35/24-Z35/38	300	230	265	234				14	144		20	M12	1.8/4.0
	160	PT 350-A-080-188	RA 28/38-Z45/24-Z45/42	350	250	300	260				18	188		26	M16	3.1/6.8
KF 100...200	100/112	PT 250-A-110-135	RA 24/28-Z30/28-Z30/28	250	180	215	190	110	7	145	14	135	M12	18	M12	1.4/3.1
	132	PT 300-A-110-168	RA 28/38-Z35/28-Z35/38	300	230	265	234				14	168		20		M12
	160	PT 350-A-110-188	RA 38/45-Z45/28-Z45/42	350	250	300	260				18	188		26	M16	2.9/6.4
	180	PT 350-A-110-204	RA 42/55-Z50/28-Z50/48								18	204				26
KF 100...150 Seal 31	100/112	PT 250-A-110-135	RS 24-Z30/24-Z30/28	250	180	215	190	110	7	145	14	135	M12	18	M12	1.4/3.1
	132	PT 300-A-110-144	RS 28-Z35/24-Z35/38	300	230	265	234				14	144		20		M12
	160	PT 350-A-110-188	RS 38-Z45/24-Z45/42	350	250	300	260				18	188		26	M16	2.9/6.4
	180	PT 350/A-110-204	RG 42/55-Z50/24-Z75/48								18	204				26
KF 180...200 Seal 31	100/112	PT 250-A-110-135	RS 24-Z30/24-Z30/28	250	180	215	190	110	7	145	14	135	M12	18	M12	1.4/3.1
	132	PT 300-A-110-168	RS 28-Z35/24-Z60/38	300	230	265	234				14	168		20		M12
	160	PT 350-A-110-188	RS 38-Z45/24-Z45/42	350	250	300	260				18	188		26	M16	2.9/6.4
	180	PT 350-A-110-204	RG 42/55-Z50/24-Z50/48								18	204				26
KF 250...630	132	PT 300-A-160-196	RA 28/38-Z35/38-Z35/38	300	230	265	234	160	7	200	14	196	M16	20	M12	1.8/4.0
	160	PT 350-A-160-228	RA 38/45-Z45/38-Z45/42	350	250	300	260				18	228		26		M16
	180	PT 350-A-160-228	RA 42/55-Z50/38-Z50/48								18	228			26	
	200	PT 400-A-160-228	RA 42/55-Z50/38-Z50/55	400	300	350	300				18	262		26	M16	5.0/11.0
	225	PT 450-A-160-262	RA 48/62-Z56/38-Z56/60	450	350	400	350				18	262		26	M16	6.7/14.8
	250	PT 550-A-160-265	RG 55/74-Z65/38-Z65/65	550	450	500	450				6	265		26	M16	7.4/16.3

Hub material RA = Aluminium, RG = Grey cast iron, RS = Steel

Working temperature: -20 ... 80 °C / -4 ... 176 °F (short duration temperature peaks up to 120 °C / 248 °F are permissible).

Motor-Pump Assemblies with Pipe Thread

KF 2.5...25

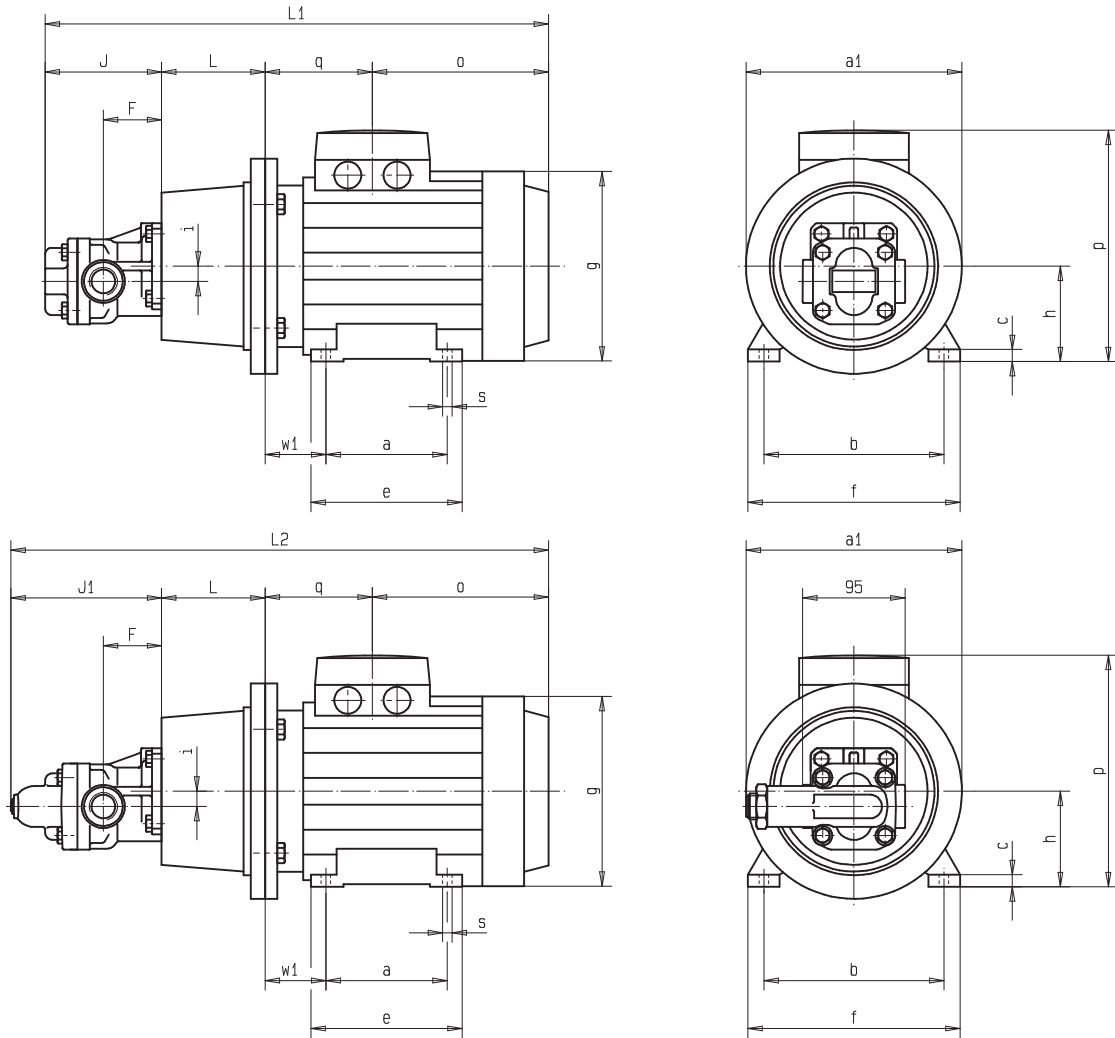

with pressure relief valve

KF 2.5...25 Pump sizes (in mm)

Nominal size	Pump sizes			
	F	J	J ₁	i
2.5...12	54	108	140	14.2
16...25	63	130	162	14.2

Motor-Pump Assemblies with Pipe Thread

KF 2.5...25

Size	Power Speed Motor 6 pole		Power Speed Motor 4 pole		Bell housing	Coupling	Total weight * [kg/lbs]	
	kW	rpm	kW	rpm			Nominal size 4...12 16...25	
71	0.18	880	0.25	1350	PT160-A-063-80	RA19-Z25/14-Z25/14	11.5/25.4	12.1/26.7
71	0.25	900	0.37	1370			11.5/25.4	12.1/26.7
80	0.37	900	0.55	1370	PT200-A-063-100	RA19-Z25/14-Z25/19	13.5/29.8	14.1/31.1
80	0.55	900	0.75	1420			15.5/34.2	16.1/35.5
90 S	0.75	935	1.1	1425	PT200-A-063-100	RA19/24-Z25/14-Z25/24	17.5/38.6	18.1/39.9
90 L	1.1	935	1.5	1420			20.5/45.2	21.1/46.5
100	1.5	940	2.2	1430	PT250-A-063-120	RA24/28-Z30/14-Z30/28	25.5/56.2	26.1/46.5
100	–	–	3	1430			28.5/62.8	29.1/64.2
112	2.2	940	4	1435			35.0/77.2	35.6/78.5

* with pressure relief valve add, weight 0.8 kg / 1.8 lbs

KF 2.5...25 Dimensions

Size	Dimensions (in mm)																			
	4...12 16...25		4...12 16...25		L	i	a ₁	a	b	c*	e*	f*	g*	h	o*	p*	q*	ø s*	w ₁	
	L ₁ *	L ₁ *	L ₂ *	L ₂ *																
71	413	435	445	467	80	14.2	160	90	112	10	101	137	144	71	158	188	67	7	45	
80	458	480	490	512	100	14.2	200	100	125	10	122	155	164	80	170.5	217	79.5	10	50	
90 S	468	490	500	522	100	14.2	200	100	140	12	125	175	180	90	177.5	235	82.5	10	56	
90 L	493	515	525	547	100	14.2	200	125	140	12	150	175	180	90	202.5	235	82.5	10	56	
100	554	576	586	608	120	14.2	250	140	160	14	173	198	205	100	247.5	252	78.5	12	63	
112	563	585	595	617	120	14.2	250	140	190	14	172	228	222	112	247.0	292	88	12	70	

Note: Flange connection same outer dimensions as for pipe connection

Note

* Dimensions dependent on motor typ (drawing: manufacture ADDA).

Other manufactures motors can be supplied on request.

Motor frame sizes are based on DIN 42673/677.

All pump and motor sizes can be combined.

Motor-Pump Assemblies with SAE-Connection

KF 32...80

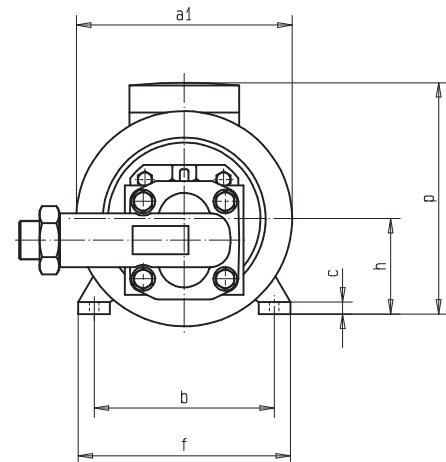
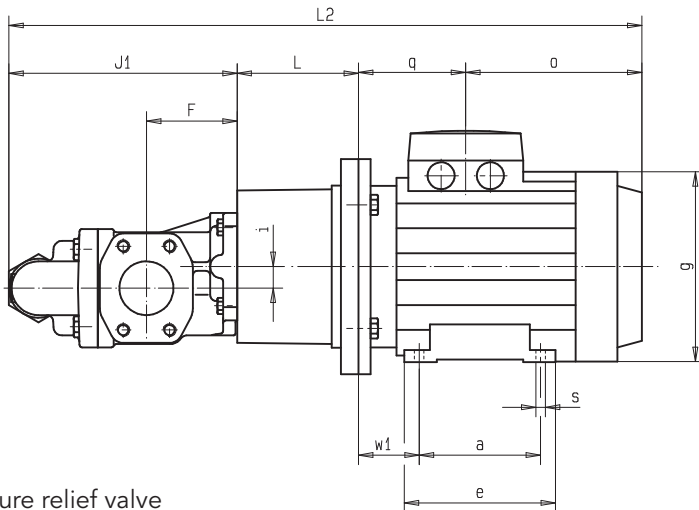
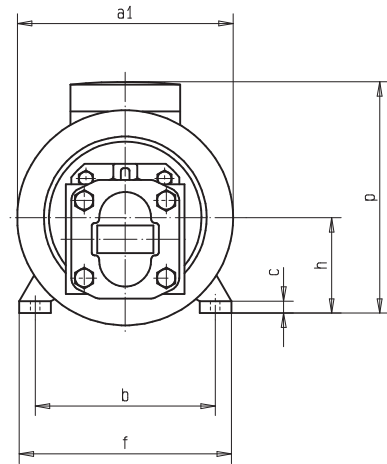
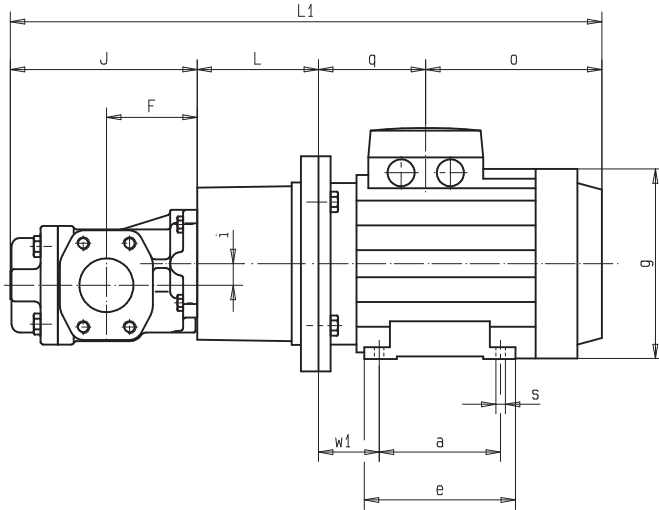

with pressure relief valve

KF 32...80 Pump sizes (in mm)

Nominal size	F	J	J ₁	i
32...50	84	172	211.5	20
63/80	100	207	246.5	20

Motor-Pump Assemblies with SAE-Connection

KF 32... 80

Size	Power Speed Motor 6 pole		Power Speed Motor 4 pole		Bell housing	Coupling	Total weight * [kg/lbs]	
	kW	rpm	kW	rpm			Nominal size 32...50 63...80	
80	0.37	900	0.55	1370	PT200-A-080-100	RA19/24-Z25/24-Z25/19	18.5/40.8	19.5/43.0
80	0.55	900	0.75	1420			19.5/43.0	21/46.3
90 S	0.75	935	1.1	1425	PT200-A-080-110	RA24-Z30/24-Z30/24	21.0/46.3	23.0/50.7
90 L	1.1	935	1.5	1420			23.5/51.8	25.5/56.2
100	–	–	2.2	1430	PT250-A-080-124	RA24/28-Z30/24-Z30/28	29.5/65.0	31.0/65.0
100	1.5	940	3	1430			32.0/70.5	34.0/75.0
112	2.2	940	4	1435			38.5/84.9	40.0/88.2
132 S	3	940	5.5	1430	PT300-A-080-144	RA28/38-Z35/24-Z35/38	49.5/109.1	51.5/113.5
132 M	4	945	7.5	1430			59/130.1	60.5/133.4
132 L	5.5	945	–	–			61/134.5	62.5/137.8
160 M	7.5	955	11	1440	PT350-A-080-188	RA38/45-Z45/24-Z45/42	81/178.6	82.5/181.9
160 L	11	960	15	1445			101/222.7	102.5/226.0

* with pressure relief valve add. weight 1.8 kg / 4.0 lbs

KF 32... 80 Dimensions

Size	Dimensions (in mm)																			
	32...50 63...80				32 - 80															
	L ₁ *	L ₁ *	L ₂ *	L ₂ *	L	i	a ₁	a	b	c*	e*	f*	g*	h	o*	p*	q*	ø s*	w ₁	
80	522	557	561.5	596.5	100	20	200	100	125	10	122	155	164	80	170.5	217	79.5	10	50	
90 S	542	577	581.5	616.5	110	20	200	100	140	12	125	175	180	90	177.5	235	82.5	10	56	
90 L	567	602	606.5	641.5	110	20	200	125	140	12	150	175	180	90	202.5	235	82.5	10	56	
100	622	657	661.5	696.5	124	20	250	140	160	14	173	198	205	100	247.5	252	78.5	12	63	
112	631	666	670.5	705.5	124	20	250	140	190	14	172	228	222	112	247	292	88	12	70	
132 S	672	707	711.5	746.5	144	20	300	140	216	16	225	258	264	132	262	325	94	12	89	
132 M	711	746	750.5	785.5	144	20	300	178	216	16	225	258	264	132	301	325	94	12	89	
160 M	855	890	894.5	929.5	188	20	350	210	254	17	332	315	325	160	323	410	172	14.5	108	
160 L	900	935	939.5	974.5	188	20	350	254	254	17	332	315	325	160	368	410	172	14.5	108	

Note

* Dimensions dependent on motor typ (drawing: manufacture ADDA).
Other manufactures motors can be supplied on request.
Motor frame sizes are based on DIN 42673/677.

All pump and motor sizes can be combined.

Motor-Pump Assemblies with SAE-Connection

KF 100...200

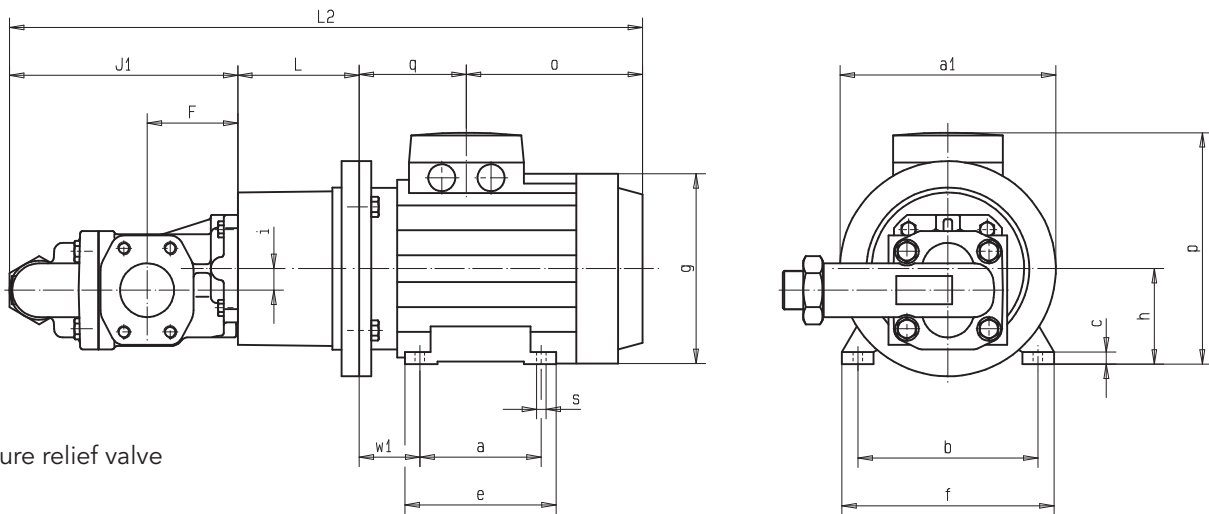
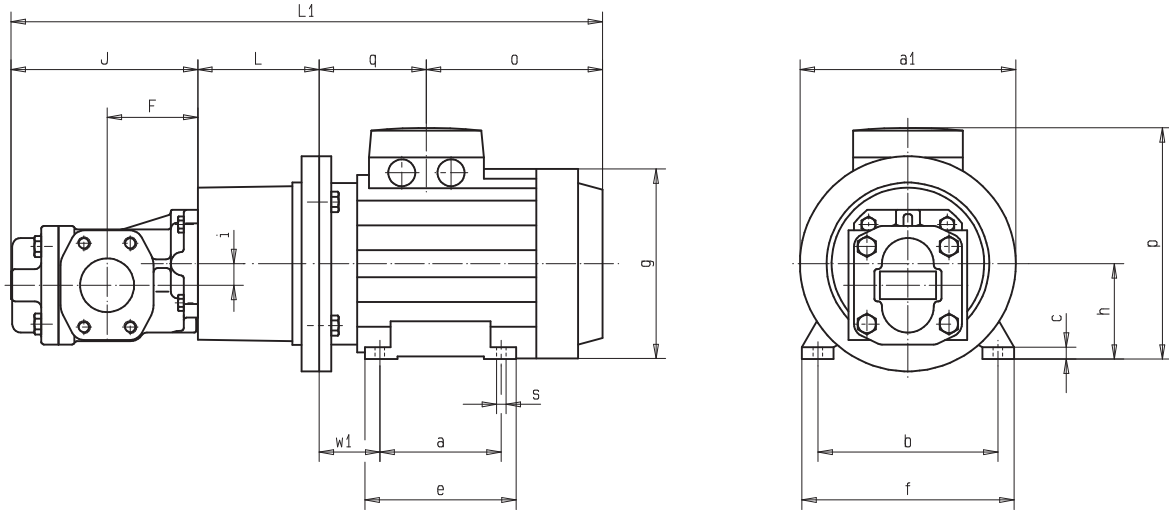

with pressure relief valve

KF 100...200 Pump sizes (in mm)

Nominal-size	F	J	J ₁	i
100/112	102	220.5	262.5	23.7
125/150	120	245	282	23.7
180/200	130	261.5	298.5	23.7

Motor-Pump Assemblies with SAE-Connection

KF 100...200

Size	Power Speed Motor 6 pole		Power Speed Motor 4 pole		Bell housing	Coupling	Total weight * [kg/lbs]		
	kW	rpm	kW	rpm			Nominal size		
							100/112	125/150	180/200
100 L	–	–	2.2	1430	PT250-A-110-135	RA24/28-Z30/28-Z30/28 **RS24/Z30/24-Z30/28	45.0/99.2	51.0/112.4	53.5/117.9
100 L	1.5	940	3	1430			45.5/100.3	51.5/113.5	54.0/119.1
112 M	2.2	940	4	1435			50.5/111.3	52.0/114.6	59.0/130.1
132 S	3	940	5.5	1430	PT300-A-110-168 **PT300-A-110-144	RA28/38-Z35/28-Z35/38 **RS28/Z35/24-Z35/38	64.0/141.1	70.5/155.4	73.0/160.9
132 M	4	945	7.5	1430			76.0/167.6	81.5/179.7	84.0/190.7
132 L	5.5	945	–	–			78.0/172.0	84.0/185.2	86.5/190.7
160 M	7.5	955	11	1430	PT350-A-110-188	RA38/45-Z45/28-Z45/42 **RS38/Z45/24-Z45/42	100.0/220.5	106.5/234.8	109.5/241.4
160 L	11	960	15	1440			117.0/257.9	125.0/275.6	125.5/276.7
180 M	–	–	18.5	1445	PT350-A-110-204	RA42/55-Z50/28-Z50/48 **RG42/55-Z50/24-Z50/48	152.0/335.1	158.0/348.3	161.5/356.0
180 L	15	960	22	1460			154.0/339.5	160.0/352.7	162.5/358.3

** with pressure relief valve KF 100-200 add. weight 2.7 kg / 6.0 lbs

** Sealing version 31

KF 100...200 Dimensions

Size	Dimensions (in mm)																			
	100/112 125/150 180/200			100/112 125/150 180/200																
	L ₁ *	L ₁ *	L ₁ *	L ₂ *	L ₂ *	L ₂ *	L	a ₁	a	b	c*	e*	f*	g*	h	o*	p*	q*	ø _s *	w ₁
100	681.5	706	722.5	723.5	743	759.5	135	250	140	160	14	178	198	205	100	247.5	252	78.5	12	63
112	690.5	715	731.5	732.5	752	768.5	135	250	140	190	14	172	228	222	112	247	292	88	12	70
132 S	744.5	769	785.5	786.5	806	822.5	168	300	140	216	16	225	258	264	132	262	325	94	12	89
132 M	783.5	808	824.5	825.5	845	861.5	168	300	178	216	16	225	258	264	132	301	325	94	12	89
160 M	903.5	928	944.5	945.5	965	981.5	188	350	210	254	17	332	315	325	160	323	410	172	15	108
160 L	948.5	973	959.5	990.5	1010	1026.5	188	350	254	254	17	332	315	325	160	368	410	172	15	108
180 M	1001.5	1026	1042.5	1043.5	1063	1079.5	204	350	241	279	27	320	350	360	180	336	450	241	15	121
180 L	1039.5	1064	1080.5	1081.5	1101	1117.5	204	350	279	279	27	320	350	360	180	354	450	261	15	121

Note

* Dimensions dependent on motor typ (drawing: manufacture ADDA).
Other manufactures motors can be supplied on request.
Motor frame sizes are based on DIN 42673/677.

All pump and motor sizes can be combined.

Motor-Pump Assemblies with SAE-Connection

KF 250...630

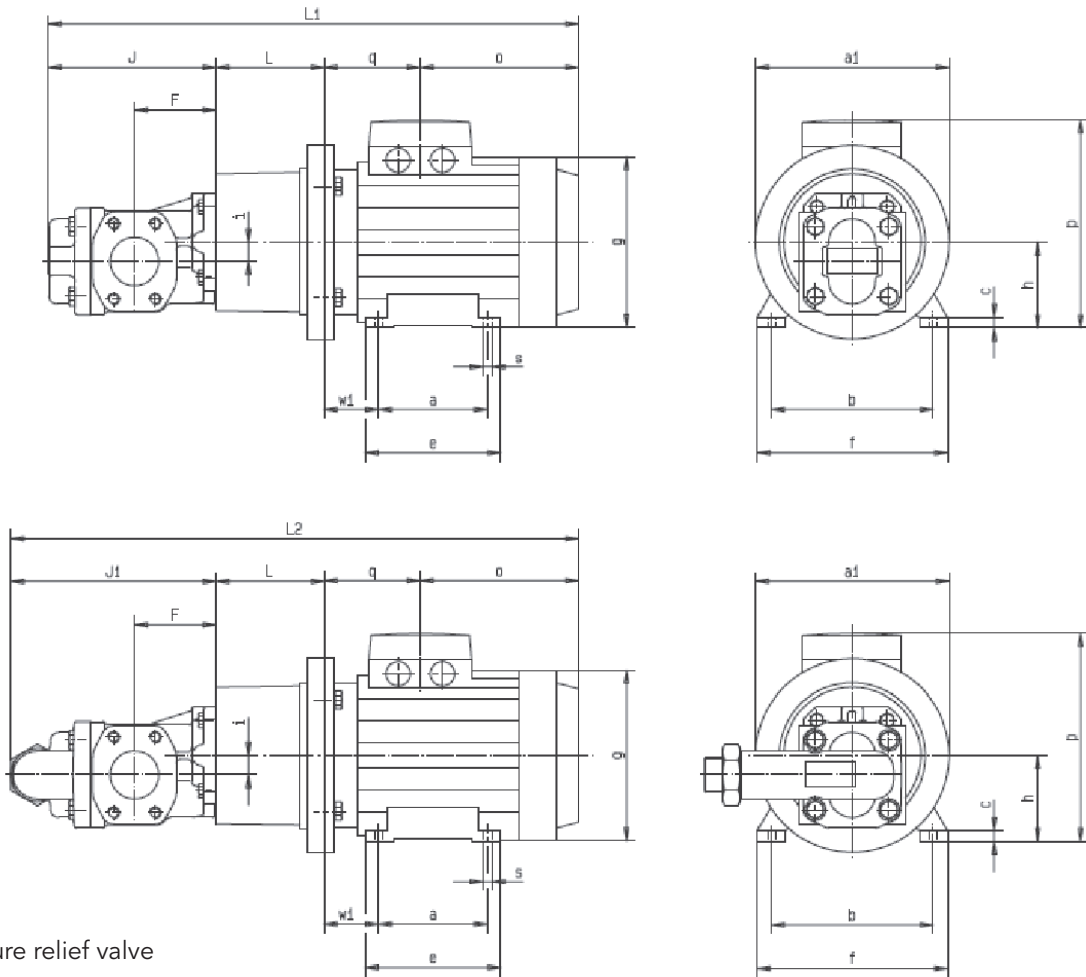

with pressure relief valve

KF 250...630 Pump sizes (in mm)

Nominal-size	F	J	J ₁
250/315	155	311	364
400/500	200	373	426
630	200	417	470

Motor-Pump Assemblies with SAE-Connection

KF 250...630

Size	Power Speed Motor 6-pole		Power Speed Motor 4-pole		Bell housing	Coupling	Total weight * [kg/lbs]		
	kW	rpm	kW	rpm			Nominal size 250/315 400/500 630		
132 S	3	940	5.5	1430	PT 300-A-160-196	RA 28/38-Z35/38-Z35/38	92.0/202.8	103.0/227.1	109.0/240.3
132 M	4	945	7.5	1430			103.0/227.1	114.0/251.3	120.0/264.6
160 M	7.5	955	11	1440	PT 350-A-160-228	RA 38/45-Z45/38-Z45/42	129.0/264.6	139.0/306.4	146.0/321.9
160 L	11	960	15	1440			145.0/319.7	156.0/343.9	162.0/357.1
180 M	-	-	18.5	1445		RA 42/55-Z50/38-Z50/48	181.0/399.0	192.0/423.3	198.0/436.5
180 L	15	960	22	1460			182.0/401.2	193.0/425.5	199.0/438.7
200 M	18.5	965	30	1460	PT 400-A-160-228	RA 42/55-Z50/38-Z50/55	207.0/456.4	216.0/476.2	222.0/489.4
200 L	22	965	-	-			207.0/456.4	216.0/476.2	222.0/489.4
225 S	-	-	37	1470	PT 450-A-160-262	RA 48/62-Z56/38-Z56/60	284.0/626.1	294.0/648.2	300.0/661.4
225 M	30	975	45	1480			316.0/696.7	327.0/720.9	333.0/734.1
250 M	37	975	55	1480	PT 550-A-160-265	RG 55/74-Z65/38-Z65/65	378.0/833.3	389.0/857.6	395.0/870.8

* with pressure relief valve KF 250...630 add. weight 3.5 kg / 7.7 lbs

KF 250... 630 Dimensions

Size	Dimensions (in mm)																			
	250/315		400/500		630		L	a ₁	a	b	c*	e*	f*	g*	h	o*	p*	q*	ø _s *	w ₁
	L ₁ *	L ₂ *	L ₁ *	L ₂ *	L ₁ *	L ₂ *														
132 S	863	916	925	978	969	1022	196	300	140	216	16	225	258	264	132	262	325	94	12	89
132 M	902	955	964	1017	1008	1061	196	300	178	216	16	225	258	264	132	301	325	94	12	89
160 M	1034	1087	1096	1149	1140	1193	228	350	210	254	17	332	315	325	160	323	410	172	15	108
160 L	1079	1132	1141	1194	1185	1238	228	350	254	254	17	332	315	325	160	368	410	172	15	108
180 M	1116	1169	1178	1231	1222	1275	228	350	241	279	27	320	350	360	180	336	450	241	15	121
180 L	1154	1207	1216	1269	1260	1313	228	350	279	279	27	320	350	360	180	354	450	261	15	121
200 L	1197	1250	1259	1312	1303	1356	228	400	305	318	25	358	388	399	200	373	500	285	19	133
225 S	1247	1300	1309	1362	1353	1406	262	450	286	356	28	361	436	465	225	391	560	283	19	149
225 M	1272	1325	1334	1387	1378	1431	262	450	311	356	28	386	436	465	225	404	560	295	19	149
250 M	1354	1407	1416	1469	1460	1513	265	550	349	406	30	443	484	506	250	436	616	342	24	168

Note

* Dimensions dependent on motor typ
(drawing: manufacture ADDA).
Other manufactures motors can be supplied on request.
Motor frame sizes are based on DIN 42673/677.

All pump and motor sizes can be combined.

Accessory Connections

SAE-Threaded Flange

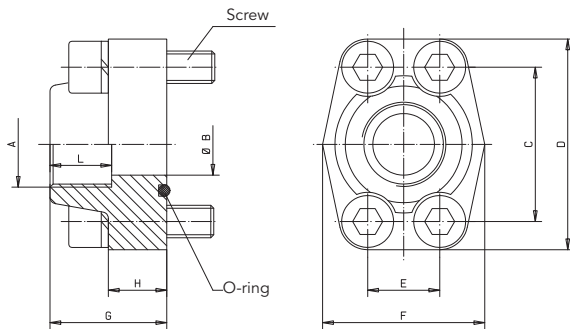

SAE-Welding Flange

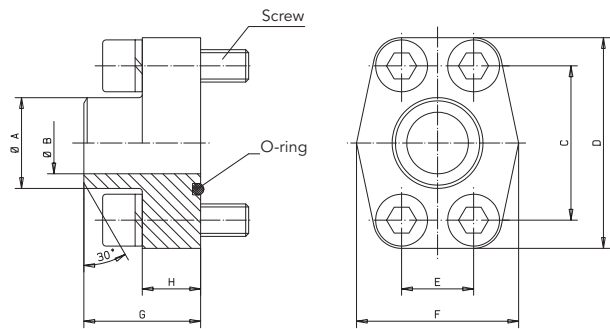

SAE-Threaded Flange Dimensions (in mm)

Nominal size SAE	A	B max.	C	D*	E	F*	G	H*	L min.	Screws 10.9	O-ring	Working pressure max.** [bar/psi]	Weight approx. [kg/lbs]
3/4"	G 1/2"	13	47.63	65	22.23	50	36	18	14	M 10 x 35	24.99 x 3.53	350/5076	0.54/1.19
	G 3/4"	19							16				0.51/1.12
1"	G 1/2"	13	52.37	70	26.19	55	38	18	14	M 10 x 35	32.92 x 3.53	315/4569	0.64/1.41
	G 3/4"	19							16				0.61/1.34
	G 1"	25							18				0.58/1.28
1 1/4"	G 3/4"	19	58.72	79	30.18	68	41	21	16	M 10 x 40	37.69 x 3.53	250/3626	0.92/2.03
	G 1"	25							18				0.88/1.94
	G 1 1/4"	32							20				0.79/1.74
1 1/2"	G 1"	25	69.85	93	35.71	78	45	25	18	M 12 x 45	47.22 x 3.53	200/2901	1.36/3.00
	G 1 1/4"	32							20				1.30/2.87
	G 1 1/2"	38							22				1.25/2.76
2"	G 1"	25	77.77	102	42.88	90	45	25	18	M 12 x 45	56.74 x 3.53	200/2901	1.64/3.62
	G 1 1/4"	32							20				1.60/3.53
	G 1 1/2"	38							22				1.45/3.20
	G 2"	51							26				1.39/3.06
2 1/2"	G 2"	51	88.90	114	50.80	105	50	25	26	M 12 x 45	69.44 x 3.53	160/2321	1.65/3.64
	G 2 1/2"	63							30				1.60/3.53
3"	G 2 1/2"	63	106.38	134	61.93	124	50	27	30	M 16 x 50	85.32 x 3.53	138/2002	2.68/5.91
	G 3"	73											30
3 1/2"	G 3"	73	120.65	152	69.85	136	48	27	30	M 16 x 50	98.02 x 3.53	35/508	2.93/6.46
	G 3 1/2"	89											30
4"	G 3 1/2"	89	130.20	162	77.80	146	48	27	30	M 16 x 50	110.72 x 3.53	35/508	3.42/7.54
	G 4"	99											30

SAE-Welding Flange Dimensions (in mm)

Nominal size SAE	A*	B max.	C	D*	E	F*	G	H*	Screws 10.9	O-ring	Working pressure max.** [bar/psi]	Weight approx. [kg/lbs]
3/4"	28.0	19	47.63	65	22.23	50	36	18	M 10 x 35	24.99 x 3.53	350/5076	0.51/1.12
1"	34.0	25	52.37	70	26.19	55	38	18	M 10 x 35	32.92 x 3.53	315/4569	0.58/1.28
1 1/4"	42.8	32	58.72	79	30.18	68	41	21	M 10 x 40	37.69 x 3.53	250/3626	0.79/1.74
1 1/2"	48.6	38	69.85	93	35.71	78	44	25	M 12 x 45	47.22 x 3.53	200/2901	1.25/2.76
2"	61.0	51	77.77	102	42.88	90	45	25	M 12 x 45	56.74 x 3.53	200/2901	1.39/3.53
2 1/2"	77.0	63	88.90	114	50.80	105	50	25	M 12 x 45	69.44 x 3.53	160/2321	1.60/3.53
3"	92.0	73	106.38	134	61.93	124	50	27	M 16 x 50	85.32 x 3.53	138/2002	2.58/5.69
3 1/2"	103.0	89	120.65	152	69.85	136	48	27	M 16 x 50	98.02 x 3.53	35/508	2.83/6.24
4"	115.5	99	130.2	162	77.8	146	48	27	M 16 x 50	110.72 x 3.53	35/508	3.27/7.21

* Dimensions depending on the manufacturer ** O-ring material with hardness 90 Shore A
 Material: Steel S355J2G3 or equivalent Stainless steel 1.4404 or equivalent

Product Portfolio

Gear Pumps

Gear pumps for lubricating oil supply equipment, low pressure filling and feed systems, dosing and mixing systems.

Hydraulics

Single and multistage high pressure gear pumps and hydraulic motors for construction machinery, vehicle-mounted machines.

Flow Measurement

Gear, turbine and screw type flow meters and electronics for volume and flow metering technology in hydraulics, processing and laquering technology.

Valves

Cetop directional control and proportional valves, pressure, quantity and stop valves for pipe and slab construction.



KF2.5...630/USA/11.19

KRACHT®