

KRACHT

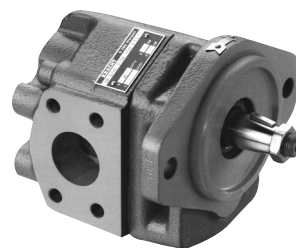
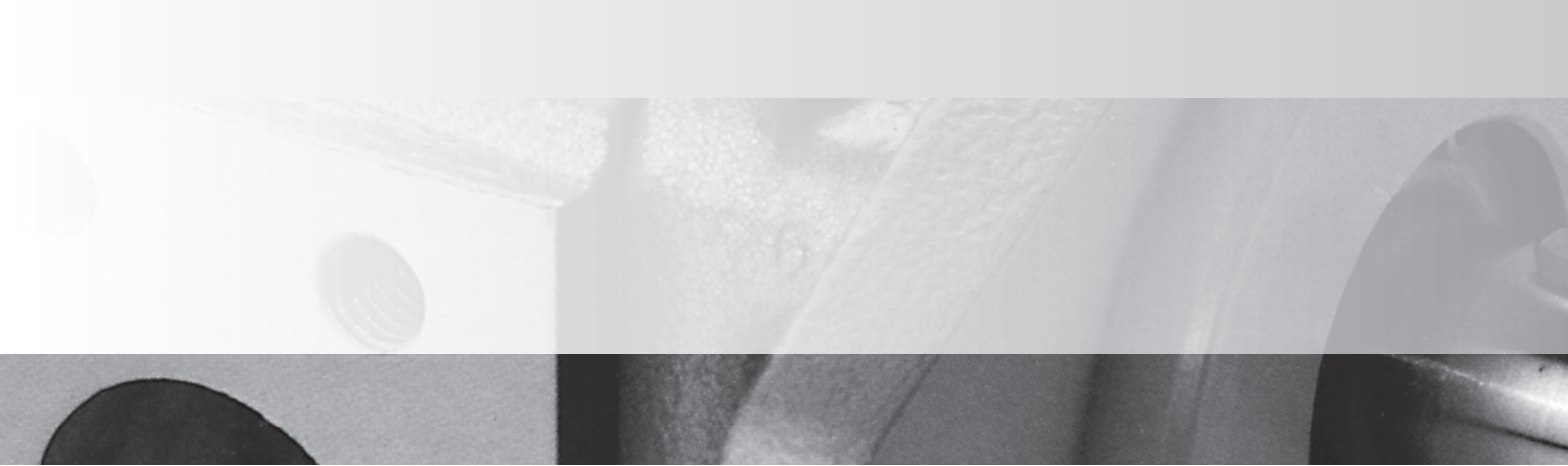

High Pressure Gear Pumps

KP 2 / KP 3

Construction

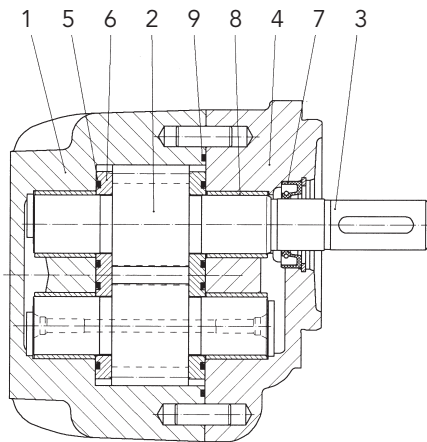

- 1 Housing
- 2 Gear
- 3 Drive shaft end
- 4 Flange mounting cover
- 5 Gasket for the pressure fields for axial and play compensation
- 6 Sliding plates
- 7 Single rotary shaft lip
- 8 Plain bearings
- 9 Sealing of the housing

Function

Due to the construction (design principle) and the materials used KRACHT series KP 2 / KP 3 external gear pumps are suitable for use under the most stringent operating conditions. The housing and the flange mounting cover (see the sectional drawing) – both made of gray cast iron – have high dynamic load capabilities and are therefore insensitive to peak pressures and permanent oscillations. Large-scale PTFE-Pb coated plain bronze bearings on steel backs in the housing and the flange mounting cover carry the extremely finely ground bearing pins of the gear, which consists of the driving shaft pinion.

The tooth profiles of the gear, which is made of case hardened steel, are ground to achieve the best running characteristics. A considerable reduction in the volume flow fluctuation and thus of the pressure pulsation is achieved through the high number of teeth ($z = 14$) and in combination with a tooth form shaped in accordance

with the special requirements of hydraulics and the optimum rating of the expansion grooves in the quench oil area. This leads to much lower noise levels for the pumps, or for complete systems and machines.

The function of the axial play compensation that is essential for high pressure pumps is carried out by the sliding plates located at the side of the gear. These have hydraulic pressure fields that guarantee compensation of the axial play on all operating pressures.

The sliding plates are designed so that play is compensated independently of the viscosity. This ensures a high degree of volumetric and mechanical efficiency at every working point.

Depending on the temperature or the media, NBR or FKM sealing gaskets can be used to meet a wide range of application requirements. Multiple pump combinations of the same or different sizes are possible.

Note

1. External loads

Loads acting on the drive shaft end from outside impair the functions of the double-land bearing.

Radial loads can be absorbed in dependence on the extent and the direction of the loads. Axial loads are not permissible.

To absorb outer loads only those pump types shall be used which are equipped with an outboard bearing.

2. Direction of rotation

Regarding the direction of rotation basically the following applies provided the view is directed toward the drive shaft end:

Drive shaft end rotating clockwise:

Flow direction from left to right.

Drive shaft end rotating anticlockwise:

Flow direction from right to left.

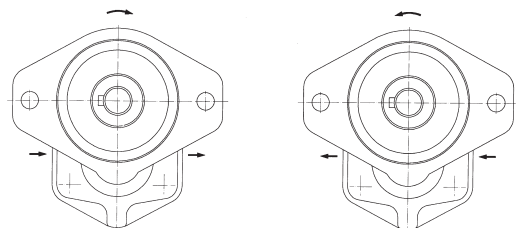

Materials

Housing	grey cast iron
Bearing	composite plain bearing bushes
Journals and gears	case hardening steel acc. to DIN 17210 surface hardened and ground
Seals	NBR rotary shaft lip type seal $\vartheta \leq 90^\circ\text{C}$ FKM rotary shaft lip type seal $\vartheta \leq 150^\circ\text{C}$

Characteristics

Mounting	flange type	
Pipe connection	flange	
Direction of rotation	clockwise or anticlockwise	
Weight	see dimension sheets	
Mounting position	optional	
Ambient temperature	$\vartheta_{u \min}$	= - 20 °C
	$\vartheta_{u \max}$	= 60 °C
Operating pressure Inlet port	$p_{e \min}$	= - 0.4 bar (vacuum)
	$p_{e \max}$	= 2 bar
Operating pressure Short time	$p_{e \max}$	= 5 bar
Operating pressure Outlet port	$p_{e \max}$	= 300 bar
Fluid temperature range	$\vartheta_{m \max}$	90 °C for NBR rotary shaft lip type seal
	$\vartheta_{m \max}$	150 °C for FKM rotary shaft lip type seal
Viscosity	v_{\min}	= 10 mm ² /s
	v_{\max}	= 600 mm ² /s
Recommended filtration	filter with filtration quotient $\beta_{25} \geq 75$ for ... 300 bar $\beta_{40} \geq 75$ for ... 100 bar	
Recommended viscosity range	v	= 30 ... 45 mm ² /s
Discharge flow	see chart page 7 and 8	
Input power	see chart page 7 and 8	
Hydraulic fluids	mineral oil acc. to DIN 51524/25 engine oil acc. to flame-retardant hydraulic fluids on request bio-oils of typ „HEES“, can be used up to 70 °C, max. pressure must be reduced minus 20 % (use only on request)	

ATEX (KP 2 only)

Products and media on request.

Calculation Formulas for Hydraulic Pumps

Characteristic data, formula signs, units

Discharge flow / input flow	Q	l/min
Pump / motor displacement	V_g	cm ³ /r
Pressure	p	bar
Speed of rotation	n	1/min
Torque	M	Nm
Power	P	kW
Total efficiency	η_{tot}	-
Volumetric efficiency	η_{vol}	-
Hydr./mech. efficiency	η_{hm}	-
Flow velocity	v	m/s
Pipe diameter	d	mm

Characteristic data for:	Volumetric flow	Discharge flow $Q = \frac{V_g \cdot n \cdot \eta_{vol}}{10^3} \left[\frac{l}{min} \right]$
	Torque	Drive torque $M = \frac{p \cdot V_g}{20 \cdot \pi \cdot \eta_{hm}} \text{ [Nm]}$
	Power	Input power $P = \frac{p \cdot Q}{600 \cdot \eta_{tot}} \text{ [kW]}$

General

$$Q_{th} = V_g \cdot n, \quad \eta_{tot} = \eta_{vol} \cdot \eta_{hm}$$

$$M = 9549 \cdot \frac{P}{n} \quad v = 21.22 \cdot \frac{Q}{d^2}$$

Approximate values for KRACHT products in the nominal operating point

	η_{tot}	η_{vol}
KP	≈ 0.90	≈ 0.95

Technical Data KP 2

Displacement Nominal size	Geom. displacement V_g cm ³ /r	Max. operating pressure p_b bar ¹⁾	Peak pressure p_{max} bar	Max. speed		Moment of inertia J kg m ²	Minimum speed				
				n_{max} 1/min ²⁾	n_{max} 1/min ³⁾		at p = ... bar 1/min				
							...100	...120	...150	...180	≥ 200
20	19.7	250	300	3000	2800	34.3	700	700	800	900	1000
25	24.6	250	300	3000	2800	40.5	600	600	700	800	900
28	27.7	230	280	2800	2500	44.3	600	600	700	800	900
32	31.5	230	280	2600	2500	49.2	500	600	700	800	900
40	39.4	210	250	2800	2200	59.0	500	600	700	800	800
50	49.2	210	250	2600	2000	71.4	500	600	700	800	800
62	61.2	180	200	2200	—	86.5	500	600	700	800	—

1) S1 or S3 mode (50 % operating factor 30 1/min)
Pressure data applies for $v \geq 30$ mm²/s and $n \geq 1000$ 1/min

2) For housing with SAE connection $\varnothing 32 / \varnothing 40$

3) For housing with connection $\varnothing 26$

Technical Data KP 3

Displacement Nominal size	Geom. displacement V_g cm ³ /r	Max. operating pressure p_b bar	Peak pressure p_{max} bar	Max. speed		Moment of inertia J kg m ²	Minimum speed				
				n_{max} 1/min	n_{max} 1/min		at p = ... bar 1/min				
							...100	...120	...150	...180	≥ 200
71	70.6	230	280	2500	2500	187	700	700	800	900	900
82	81.0	210	250	2600	2600	210	500	600	700	800	800
100	99.5	210	250	2500	2500	252	500	600	700	800	800
112	111.1	200	230	2400	2400	277	500	600	700	800	800
125	123.8	200	230	2300	2300	306	500	600	700	800	800

Discharge Flow and Required Input Power KP 2

Discharge flow at n = 1450 1/min

Nominal size	Discharge flow Q in l/min at 34 mm ² /s							
	Pressure p in bar							
	20	60	100	140	180	200	230	250
20	27.9	27.6	27.4	27.1	26.8	26.6	26.4	26.2
25	34.8	34.5	34.2	33.8	33.4	33.2	33.0	32.8
28	39.2	38.9	38.6	38.2	37.9	37.7	37.4	–
32	44.6	44.3	43.9	43.5	43.1	42.8	42.5	–
40	55.8	55.4	54.9	54.4	53.9	53.6	–	–
50	69.7	69.2	68.6	67.9	67.3	67.0	–	–
62	86.8	86.4	86.0	85.6	85.2	–	–	–

Required input power P in kW at n = 1450 1/min

Nominal size	Pressure p in bar							
	20	60	100	140	180	200	230	250
20	1.39	3.57	5.75	7.92	10.10	11.19	12.82	13.91
25	1.65	4.31	6.98	9.64	12.30	13.63	15.63	16.96
28	1.82	4.79	7.75	10.72	13.69	15.17	17.39	–
32	2.02	5.36	8.70	12.04	15.38	17.05	19.55	–
40	2.45	6.58	10.71	14.85	18.98	21.04	–	–
50	2.96	8.07	13.19	18.30	23.41	25.97	–	–
62	3.54	9.74	15.93	22.13	28.33	–	–	–

Discharge flow at n = 950 1/min

Nominal size	Discharge flow Q in l/min at 34 mm ² /s							
	Pressure p in bar							
	20	60	100	140	180	200	230	250
20	18.0	17.8	17.5	17.2	16.9	–	–	–
25	22.5	22.2	21.9	21.5	21.1	20.9	20.7	20.5
28	25.4	25.1	24.7	24.4	24.0	23.8	23.5	–
32	28.9	28.5	28.1	27.7	27.3	27.1	26.8	–
40	36.1	35.7	35.2	34.7	34.2	33.9	–	–
50	45.1	44.6	44.0	43.3	42.7	42.4	–	–
62	56.2	55.8	55.4	55.0	54.6	–	–	–

Required input power P in kW at n = 950 1/min

Nominal size	Pressure p in bar							
	20	60	100	140	180	200	230	250
20	0.91	2.34	3.76	5.19	6.61	–	–	–
25	1.08	2.82	4.57	6.31	8.06	8.93	10.24	11.11
28	1.19	3.13	5.08	7.02	8.96	9.94	11.39	–
32	1.32	3.51	5.70	7.89	10.07	11.17	12.81	–
40	1.60	4.31	7.02	9.72	12.43	13.78	–	–
50	1.93	5.28	8.63	11.98	15.33	17.01	–	–
62	2.31	6.37	10.43	14.49	18.56	–	–	–

The ratings are based on a viscosity of 34 mm²

The output of the drive motor must be chosen 20% higher than the table value P

Discharge Flow and Required Input Power KP 3

Discharge flow at n = 1450 1/min

Nominal size	Discharge flow Q in l/min at 34 mm ² /s							
	Pressure p in bar							
	20	60	100	140	180	200	210	250
71	100.1	99.4	98.7	98.0	97.2	96.8	96.6	96.2
82	114.8	114.2	113.6	112.9	112.1	111.8	111.6	–
100	141.2	140.7	140.1	139.6	139.0	138.7	138.5	–
112	157.8	157.5	157.1	156.8	156.4	156.3	–	–
125	175.8	175.5	175.1	174.7	174.3	174.1	–	–

Required input power P in kW at n = 1450 1/min

Nominal size	Pressure p in bar							
	20	60	100	140	180	200	210	250
71	4.10	11.63	19.15	26.68	34.20	37.96	39.84	43.61
82	4.67	13.31	21.94	30.57	39.21	43.52	45.68	–
100	5.63	16.13	26.63	37.13	47.63	52.87	55.50	–
112	6.20	17.79	29.39	40.98	52.58	58.38	–	–
125	6.81	19.60	32.39	45.17	57.96	64.35	–	–

Discharge flow at n = 950 1/min

Nominal size	Discharge flow Q in l/min at 34 mm ² /s							
	Pressure p in bar							
	20	60	100	140	180	200	210	250
71	64.8	64.1	63.4	62.7	61.9	61.5	61.3	60.9
82	74.3	73.7	73.1	72.4	71.6	71.3	71.1	–
100	91.4	90.9	90.4	89.8	89.2	88.9	88.8	–
112	102.2	101.9	101.6	101.2	100.9	100.7	–	–
125	113.9	113.6	113.2	112.8	112.4	112.2	–	–

Required input power P in kW at n = 950 1/min

Nominal size	Pressure p in bar							
	20	60	100	140	180	200	210	250
71	2.68	7.61	12.54	17.47	22.40	24.87	26.10	28.57
82	3.06	8.71	14.37	20.03	25.68	28.51	29.93	–
100	3.69	10.57	17.44	24.32	31.20	34.64	36.36	–
112	4.06	11.65	19.25	26.85	34.44	38.24	–	–
125	4.46	12.83	21.21	29.59	37.97	42.16	–	–

The ratings are based on a viscosity of 34 mm²/s

The output of the drive motor must be chosen 20% higher than the table value P

Type Key

Housing connection

- A** Suction and pressure connection $\varnothing 26$ with LK 55 to V_g 50
- F** Suction side 1 1/4"-SAE connection ($\varnothing 32$) to V_g size 32
Pressure side 1" SAE connection ($\varnothing 25$) to V_g size 32
- G** Suction side 1 1/2" SAE connection ($\varnothing 40$) from V_g size 40 to V_g 71
Pressure side 1 1/4" SAE connection ($\varnothing 32$) from V_g size 40 to V_g 71
- J** Suction side 2" SAE connection ($\varnothing 50$) from V_g size 82
Pressure side 1 1/4" SAE connection ($\varnothing 32$) from V_g size 82
- V** as A housing;
for multi-stage pump version
- Y** as F housing;
for multi-stage pump version
- Z** as G housing;
for multi-stage pump version
- X** as J housing;
for multi-stage pump version

Shaft end / Shaft load capacity

- B** External spline W 35 x 2; DIN 5480 from V_g 82; 800 Nm_{max}
- K** Cone 1 : 5; 500 Nm_{max}
- U** External spline SAE-B; Z = 13; DP 16/32; $\alpha = 30^\circ$; 180 Nm_{max}
- Y** Cylindrical shaft $\varnothing 24$; 230 Nm_{max} KP 2; $\varnothing 32$; 550 Nm_{max} KP 3
- W** External spline B 28 x 25; DIN 5482; Z = 15; m = 1.75; 450 Nm_{max}
- Q** External spline SAE C; Z = 14; DP 12/24; $\alpha = 30^\circ$; 500 Nm_{max}

2. Shaft end

- 0** None
- W** External spline B 28 x 25; DIN 5482; Z = 15; m = 1.75

Transition piece

- G** Transition piece for multi-stage design KP 2 with KP 1
- H** Transition piece for multi-stage design KP 2 with KP 2
- 0** Standard design (1-stage pump)
- J** KP 3 with KP 1
- L** KP 3 with KP 2 and KP 3 with KP 3

Design code

- 4** KP 2 (specified by KRACHT)
- 6** KP 3 (specified by KRACHT)

Ordering example

KP 2 / 20 S 1 0 A Y 0 0 4 D L 1 .

Housing and bearing design

- D** Grey cast iron with composite plain bearings

Outboard flanges or bearing

- 0** without

Direction of rotation

- 1** Clockwise
- 2** Anticlockwise

Flange mounting cover

- G** Square 4-hole flange, LA = 102/145; $\varnothing Z = 105$
- S** SAE-B 2-hole flange, LA = 146; $\varnothing Z = 101.6$
- M** 2-hole flange, LA 78/90; $\varnothing Z = 63$
- F** as M, but fastener drill holes laterally reversed
- T** SAE C 2-hole flange, LA = 181; $\varnothing Z = 127$
- V** SAE C 4-hole flange, LA = 114.55; $\varnothing Z = 127$

LA = Hole spacing
 $\varnothing Z$ = Centring diameter

Nominal size

- KP 2** 20/25/28/32/40/50/62
- KP 3** 71/82/100/112/125

Size 2, 3

Gear design

- L** Shaft and pin wheel made of case-hardened steel, ground tooth flanks

Seals

- 1** NBR rotary shaft lip type seals $\vartheta \leq 90^\circ\text{C}$
- 2** FKM rotary shaft lip type seals $\vartheta \leq 150^\circ\text{C}$

Product code

Code-No. for special construction

Flange Types

Square 4-hole flange G
KP 2 only

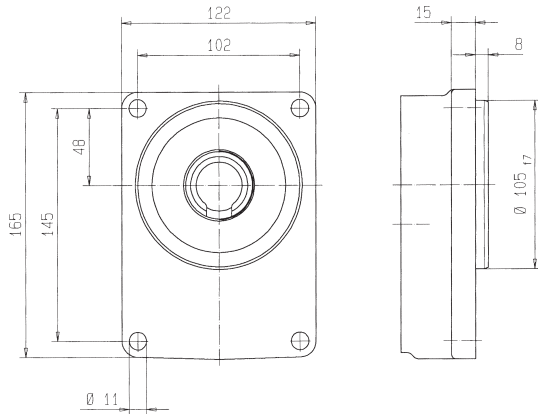

SAE B 2-hole flange S

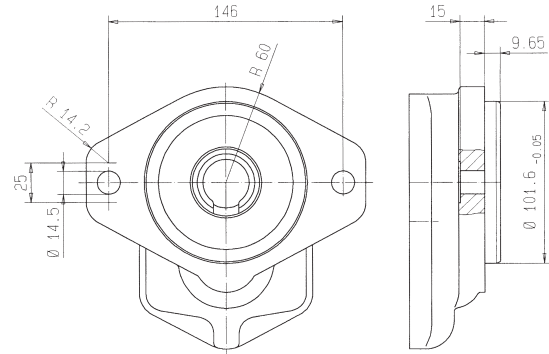

2-hole flange F
KP 2 only

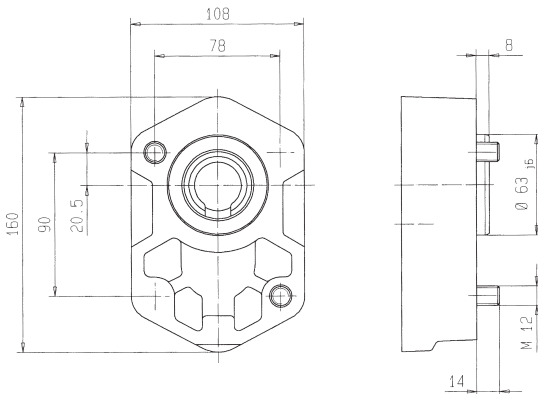

2-hole flange M
KP 2 only

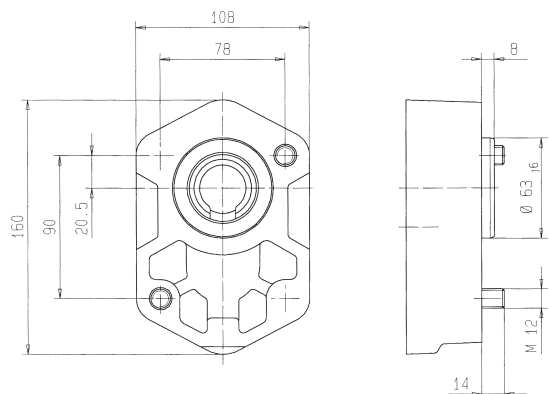

SAE C 2-hole flange T
KP 3 only

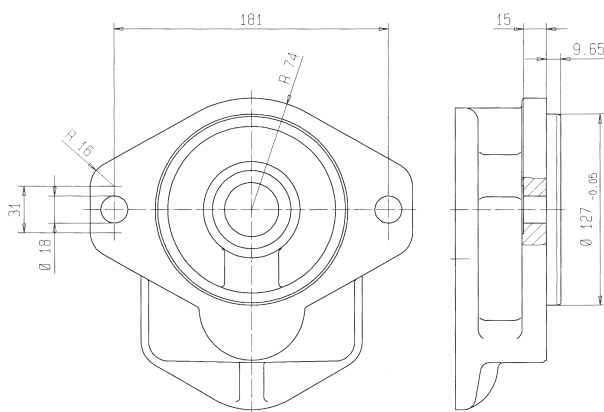

SAE C 4-hole flange V
KP 3 only

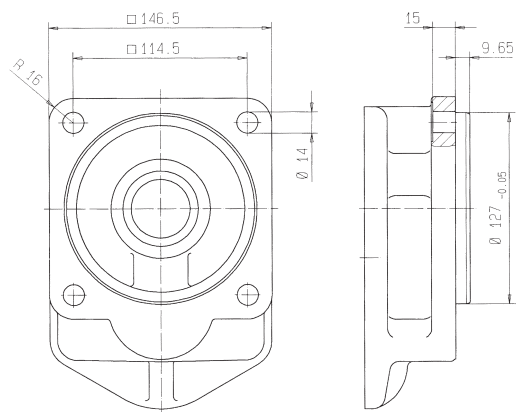

Connections

Housing connection A

Displacement nominal size

KP2: 20 – 50

Inlet and outlet ports same dimensions

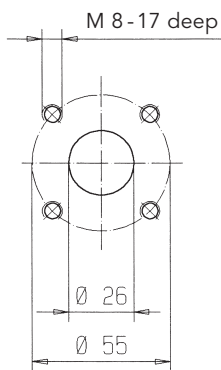

Housing connection F

Displacement nominal size

KP2: 20, 25, 28, 32

Inlet port

SAE 1 1/4

Outlet port

SAE 1

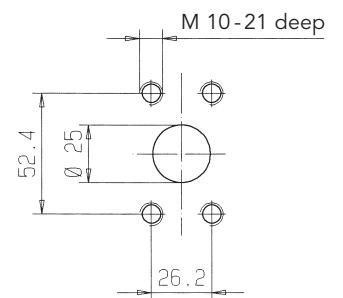
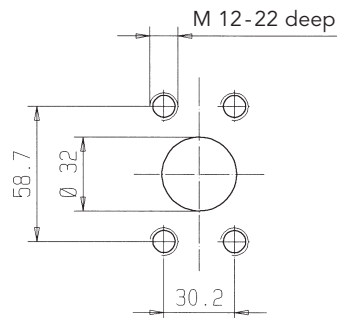

Housing connection G

Displacement nominal size

KP2: 40, 50, 62

KP3: 71

Inlet port

SAE 1 1/2

Outlet port

SAE 1 1/4

Housing connection J

Displacement nominal size

KP3: 82, 100, 112, 125

Inlet port

SAE 2

Outlet port

SAE 1 1/4

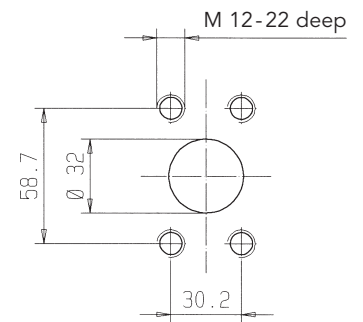
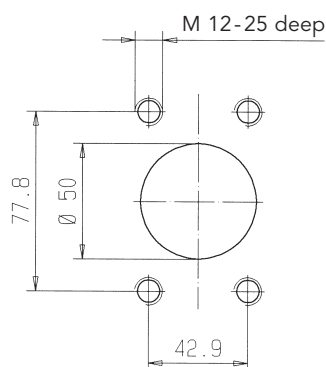
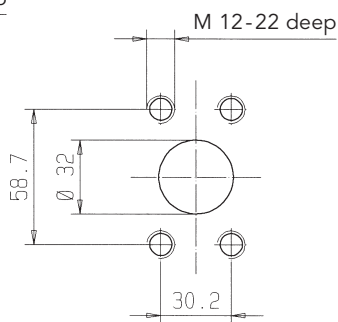
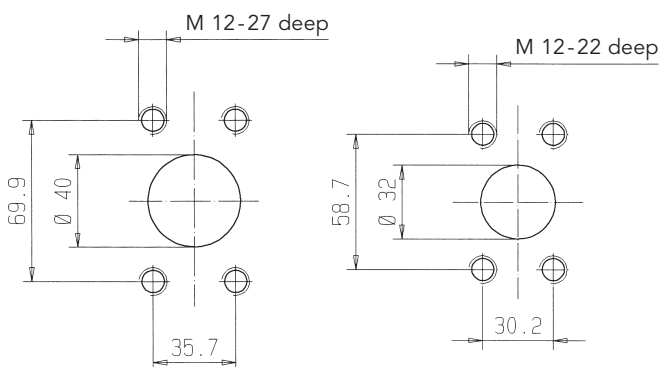

Shaft Ends KP 2

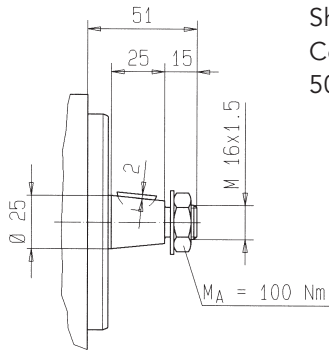

Shaft end K
Cone 1: 5
500 Nm_{max}

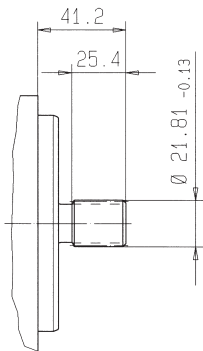

Shaft end U
External spline SAE-B
z = 13 DP 16/32, $\alpha = 30^\circ$
180 Nm_{max}

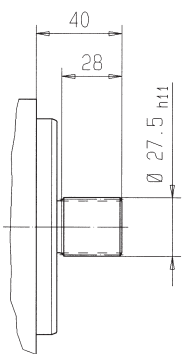

Shaft end W
External spline B 28 x 25
DIN 5482
z = 15, m = 1.75
450 Nm_{max}

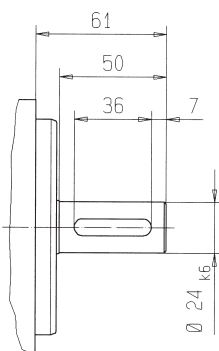

Shaft end Y
Cylindrical shaft
230 Nm_{max}

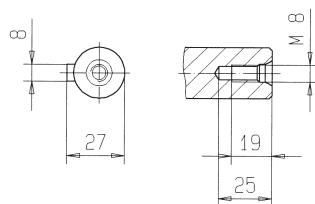

Shaft Ends KP 3

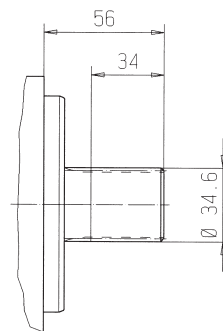

Shaft end B
External spline W 35 x 2
DIN 5480 from V_g 82
800 Nm_{max}

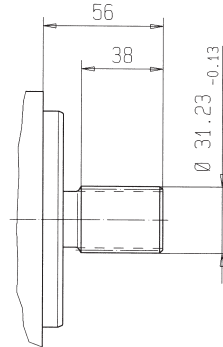

Shaft end Q
External spline SAE-C
z = 14 DP 12/24, $\alpha = 30^\circ$
500 Nm_{max}

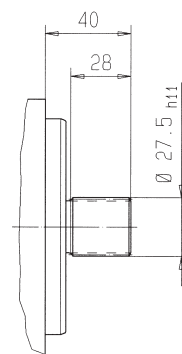

Shaft end W
External spline B 28 x 25
DIN 5482
z = 15, m = 1.75
450 Nm_{max}

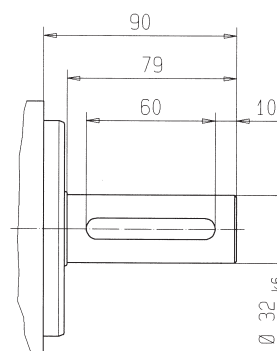

Shaft end Y
Cylindrical shaft
550 Nm_{max}

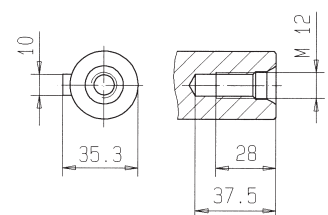

Dimensions, Weight KP 2

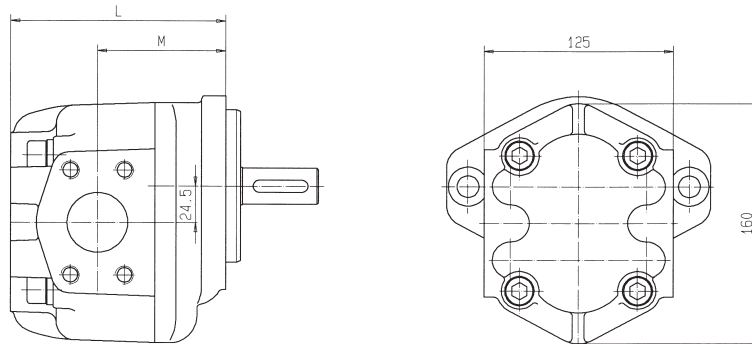

Displacement Nominal size	L	M	Weight		
			Design G flange	Design S flange	Design F/M flange
20	129	75	11	10	9
25			11.5	10.5	9.5
28			12	11	10
32			12.5	11.5	10.5
40	142	85	13	12.5	11.5
50			13.5	13	12
62			15	14	13

Dimensions, Weight KP 3

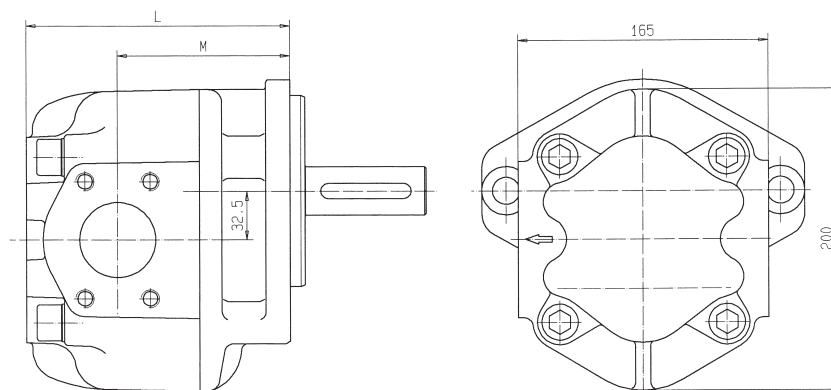

Displacement Nominal size	L	M	Weight		
			Design S flange	Design T flange	Design V flange
71	162	102	23	23.5	24
82	174	114	24.5	25	25.5
100			26	26.5	27
112	185	125	27	27.5	28
125			29	29.5	30

Tandem Version SAE-C Flange, Cylindrical Shaft

The pump stages shown here can work in hydraulically separated circuits or with different media

Direction of rotation: clockwise
With anticlockwise rotation the inlet and outlet ports are opposite

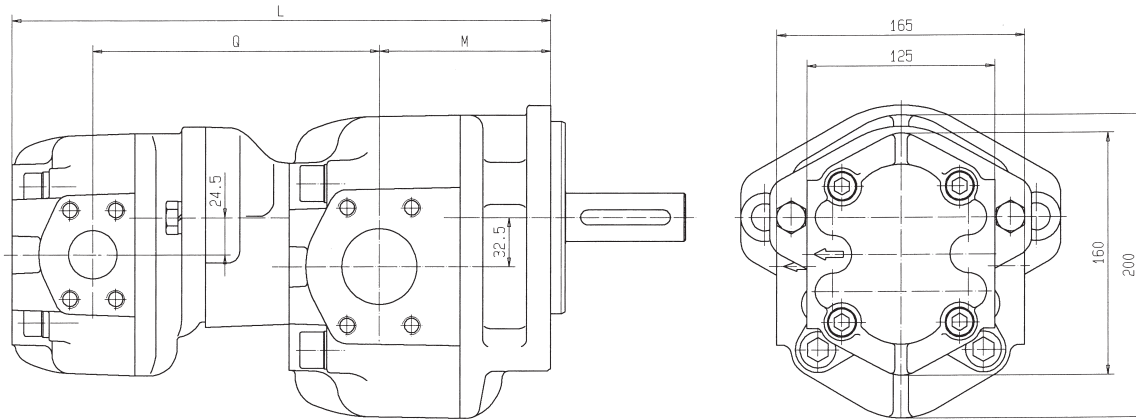

The drive should be by means of a compensating coupling!
Important: Unbalanced states and/or axial loads must not occur.

Ordering example

KP 3/100 T10X YWL 6DL1 + KP 2/32 S10F W00 4DL1

Displacement Nominal size 2 nd stage	Displacement Nominal size								
	71			82-100			112-125		
	Q	L	M	Q	L	M	Q	L	M
20	191	347	102	191	359	114	191	370	125
25									
28									
32									
40	201	360	102	201	372	114	201	383	125
50									
62									
62	201	370	102	201	382	114	201	393	125

Along with the versions shown here, the following are available on request:

- other pump combinations (KP3, KP2, KP1)
- other flange mounting cover and shaft version for the 1st stage
- three-stage pumps

Accessory – Couplings

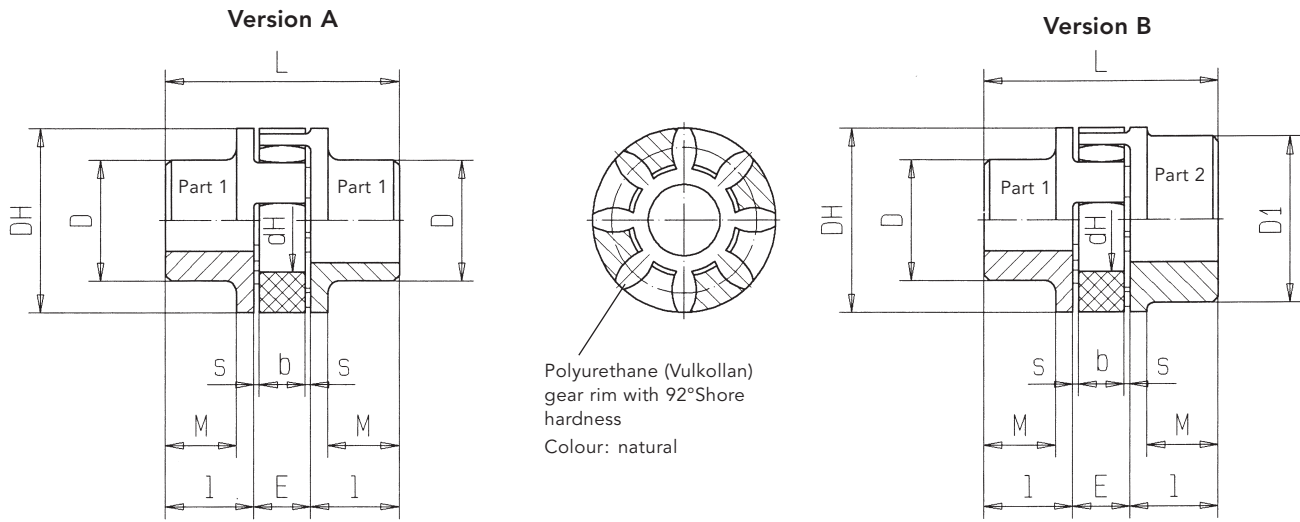

Ordering example:

R^A_G 38 - Z 45/²⁴/₃₂ - Z 45/38

	Hub material
A	AL
G	GG

Coupling size

Coupling hub length and hub drill hole on pump side cylindrical
KP2: Ø 24; KP3: Ø 32

Coupling hub length and hub drill hole on motor side cylindrical

	Coupling size	Hub material: Aluminium		Pilot hole		Finished bore				Dimensions										Ordering example
		Weight Kg	Moment of inertia Kgm ²	l Part 1	Part 2	min. Part 1	min. Part 2	max. Part 1	max. Part 2	l	E	s	b	L	M	D _H	D	D ₁	d _h	
Version A	28	0.39	0.0002	8	-	10	-	28	-	35	20	2.5	15	90	28	65	48	-	30	RA 28-Z 35/...-Z 35/..
	38	0.82	0.0007	10	-	12	-	38	-	45	24	3	18	114	37	80	66	-	38	RA 38-Z 45/...-Z 45/..
	42	1.25	0.0014	12	-	14	-	42	-	50	26	3	20	126	40	95	75	-	46	RA 42-Z 50/...-Z 50/..
	48	1.71	0.0024	13	-	15	-	48	-	56	28	3.5	21	140	45	105	85	-	51	RA 48-Z 56/...-Z 56/..
	55	6.64	0.012	18	-	20	-	55	-	65	30	4	22	160	52	120	98	-	60	RG 55-Z 65/...-Z 65/..
Version B	24/28	0.26	0.0001	6	22	8	24	24	28	30	18	2	14	78	24	55	40	48	27	RA 24/28-Z 30/...-Z 30/..
	28/38	0.46	0.0003	8	26	10	28	28	38	35	20	2.5	15	90	28	65	48	65	30	RA 28/38-Z 35/...-Z 35/..
	38/45	0.89	0.0008	10	36	12	38	38	45	45	24	3	18	114	37	80	66	76	38	RA 38/45-Z 45/...-Z 45/..
	42/55	1.39	0.0018	12	40	14	42	42	55	50	26	3	20	126	40	95	75	94	46	RA 42/55-Z 50/...-Z 50/..
	48/60	1.86	0.0030	13	46	15	48	48	60	56	28	3.5	21	140	45	105	85	102	51	RA 48/60-Z 56/...-Z 56/..
	55/70	7.37	0.016	18	52	20	55	55	70	65	30	4	22	160	-	120	98	120	60	RG 55/70-Z 65/...-Z 65/..
	65/70	10.89	0.031	20	63	22	65	65	75	75	35	4.5	26	185	-	135	115	135	68	RG 65/75-Z 75/...-Z 75/..

Operating temperature: - 10 °C to + 80 °C (short-term temperature peaks up to + 120 °C are permissible)

Weights and moments of inertia refer to max. finished bore without groove

Finished bore in accordance with ISO fit H7; parallel keys in accordance with DIN 6885 sheet 1

Motor with Pump KP 2/. S.O. Y00 4DL.

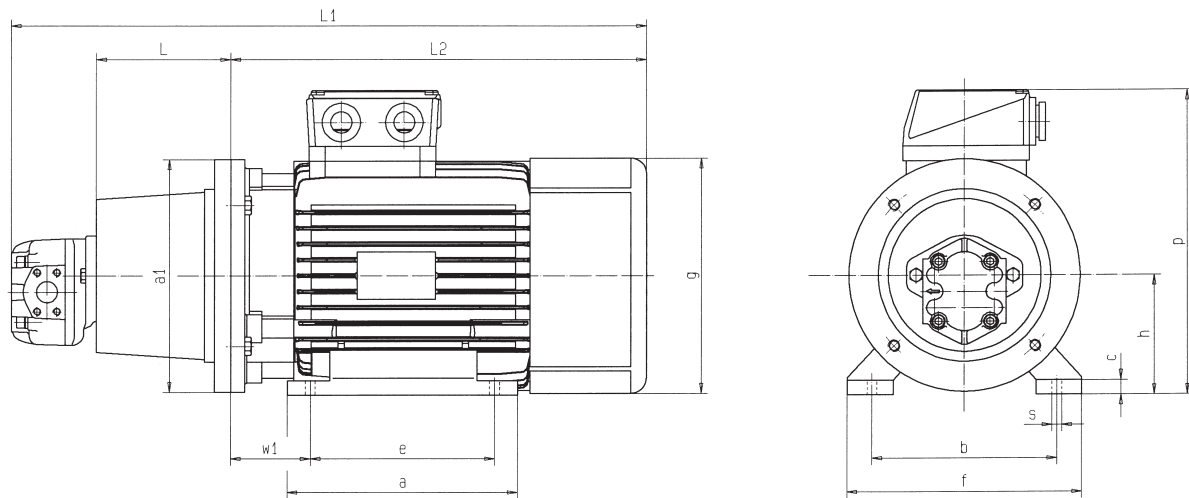

KP2

Size	Motor 6-pole		Motor 4-pole		Bell housing	Coupling
	Power kW	Speed 1/min	Power kW	Speed 1/min		
100 LA 100 LB 112 M	1.5 – 2.2	940 – 940	2.2 3.0 4.0	1420 1420 1440	Z2/250/135	RA 24/28 – Z30/24 – Z30/28
132 S 132 M	3.0 5.5	960 960	5.5 7.5	1440 1440	Z2/300/168	RA 28/38 – Z35/24 – Z35/38
160 M 160 L	7.5 11.0	970 970	11.0 15.0	1460 1470	Z2/350/188	RA 38/45 – Z45/24 – Z45/42
180 M 180 L	– 15.0	– 970	18.5 22.0	1470 1480	Z2/350/204	RA 42/55 – Z50/24 – Z50/48
200 L	22.0	970	30.0	1480	Z2/400/204	RA 42/55 – Z50/24 – Z50/55

All motor dimensions and date refer to AC motors; other motor makes on enquiry. Motor type IMB35

KP2

Size	22-32	40-50	62	20-62												
	L ₁	L ₁	L ₁	L	a ₁	a	b	c	e	f	g	h	L ₂	p	s	w ₁
100 L	589	602	612	135	250	150	160	11	140	205	187	100	325	260	12	63
112 M	604	617	627	135	250	180	190	12	140	230	210	112	340	290	12	70
132 S	700	713	723	168	300	190	216	15	140	270	248	132	403	338	12	89
132 M	727	740	750	168	300	190	216	15	178	270	248	132	430	338	12	89
160 M	822	835	845	188	350	260	254	20	210	320	312	160	505	422	15	108
160 L	877	890	900	188	350	304	254	20	254	320	312	160	560	422	15	108
180 M	923	936	946	204	350	311	279	22	241	355	354	180	590	458	15	121
180 L	963	976	986	204	350	349	279	22	279	355	354	180	630	458	15	121
200 L	993	1006	1016	204	400	370	318	25	305	395	396	200	660	525	19	133

All pump nominal sizes and motor sizes can be combined with each other

Motor with Pump KP 3/. T.O. Y00b 6DL.

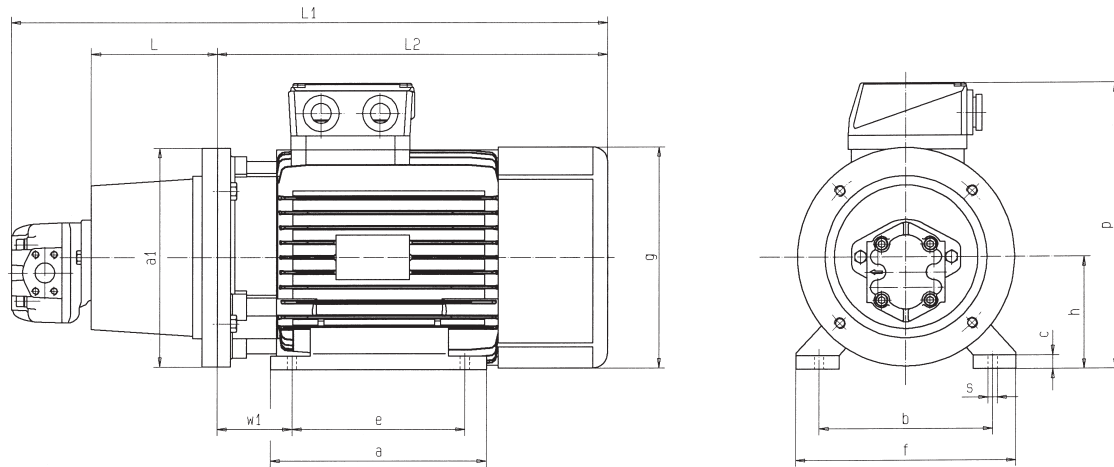

KP3

Size	Motor 6-pole		Motor 4-pole		Bell housing	Coupling
	Power kW	Speed 1/min	Power kW	Speed 1/min		
100 LA 100 LB 112 M	1.5 – 2.2	940 – 940	2.2 3.0 4.0	1420 1420 1440	Z3/250/175	RA 28/38 – Z35/32 – Z35/28
132 S 132 M	3.0 5.5	960 960	5.5 7.5	1440 1440	Z3/300/196	RA 28/38 – Z35/32 – Z35/38
160 M 160 L 180 M 180 L	7.5 11.0 – 15.0	970 970 – 970	11.0 15.0 18.5 22.0	1460 1470 1470 1480	Z3/350/228	RA 38/45 – Z45/32 – Z45/42 RA 42/55 – Z50/32 – Z50/48
200 L	22.0	970	30.0	1480	Z3/400/228	RA 42/55 – Z50/32 – Z50/55
225 S 225 M	– 30.0	– 980	37.0 45.0	1480 1480	Z3/450/262	RA 48/60 – Z56/32 – Z56/60
250 M	37.0	980	55.0	1480	Z3/550/265	RG 55/70 – Z65/32 – Z65/65
280 S	45.0	980	75.0	1480	Z3/550/265	RGS 65 – Z75/32 – Z75/75

All motor dimensions and date refer to AC motors; other motor makes on enquiry. Motor type IMB35

KP3

Size	71	82-100	112-125	71-125												
	L ₁	L ₁	L ₁	L	a ₁	a	b	c	e	f	g	h	L ₂	p	s	w ₁
100 L	662	674	685	175	250	150	160	11	140	205	187	100	325	260	12	63
112 M	677	689	700	175	250	180	190	12	140	230	210	112	340	290	12	70
132 S	761	773	784	196	300	190	216	15	140	270	248	132	403	338	12	89
132 M	788	800	811	196	300	190	216	15	178	270	248	132	430	338	12	89
160 M	895	907	918	228	350	260	254	20	210	320	312	160	505	422	15	108
160 L	950	962	973	228	350	304	254	20	254	320	312	160	560	422	15	108
180 M	980	992	1003	228	350	311	279	22	241	355	354	180	590	458	15	121
180 L	1020	1032	1043	228	350	349	279	22	279	355	354	180	630	458	15	121
200 L	1050	1062	1073	228	400	370	318	25	305	395	396	200	660	525	19	133
225 S	1099	1111	1122	262	450	368	356	28	286	435	450	225	675	574	19	149
225 M	1129	1141	1152	262	450	395	356	28	311	435	450	225	705	574	19	149
250 M	1197	1209	1220	265	550	445	406	30	349	490	490	250	770	635	24	168
280 S	1272	1284	1295	265	550	485	457	35	368	550	550	280	845	693	24	190

All pump nominal sizes and motor sizes can be combined with each other

Product Portfolio

Transfer Pumps

Transfer pumps for lubricating oil supply equipment, low pressure filling and feed systems, dosing and mixing systems.

Mobile Hydraulics

Single and multistage high pressure gear pumps, hydraulic motors and valves for construction machinery, vehicle-mounted machines.

Flow Measurement

Gear and turbine flow meters and electronics for volume and flow metering technology in hydraulics, processing and laquering technology.

Industrial Hydraulics / Test Bench Construction

Cetop directional control and proportional valves, hydraulic cylinders, pressure, quantity and stop valves for pipe and slab construction, hydraulic accessories for industrial hydraulics (mobile and stationary use).

Technology Test benches / Fluid Test benches.



KP2-KP3/GB/10.08

KRACHT