

# MSA Series

## Mechanical Diaphragm Metering pumps

Dosy Series is a mechanical diaphragm metering pump with spring return and PPS housing.

### FEATURES

■ FLOW RATE	from 10 to 90 L/h
■ MAX PRESSURE	5 bar
■ STROKE RATE	30 – 50 – 100 – 150 -166 strokes/minute
■ DIAPHRAGM DIAMETER	70 mm
■ STROKE LENGTH	4 mm



### TECHNICAL FEATURES

MODEL	DIAPHRAGM DIAMETER [mm]	STROKES RATE [Strokes/min]	FLOW RATE [L/h]	MAX PRESSURE [bar]		CONNECTIONS		MOTOR [kW]	WEIGHT [Kg]		WOODEN BOX SIZE (LxWxH) (mm)
				SS316L	PVC	SS316L	PVC		SS316L	PVC	
MSAF070P	70	30	10	5	5	1/2"gf	8x12 (Standard) DN15 (Option)	0,04	11	8	430x280x370
MSAF070O		50	20								
MSAF070N		100	40								
MSAF070M		150	60								
MSAF070R		166	90								

### PUMP HEAD MATERIALS

#### SS316L, PVC PUMP HEAD

#### PTFE DIAPHRAGM

#### MAX DOSAGE TEMPERATURE

– SS316L pump head 90° C

– PVC pump head 40° C



### MOTOR CHARACTERISTICS

■ POWER SUPPLY	380V-50HZ-3 phase 220V-50HZ-single phase
■ PROTECTION CLASS	IP55; Insulation : F

## DIMENSIONAL DRAWINGS

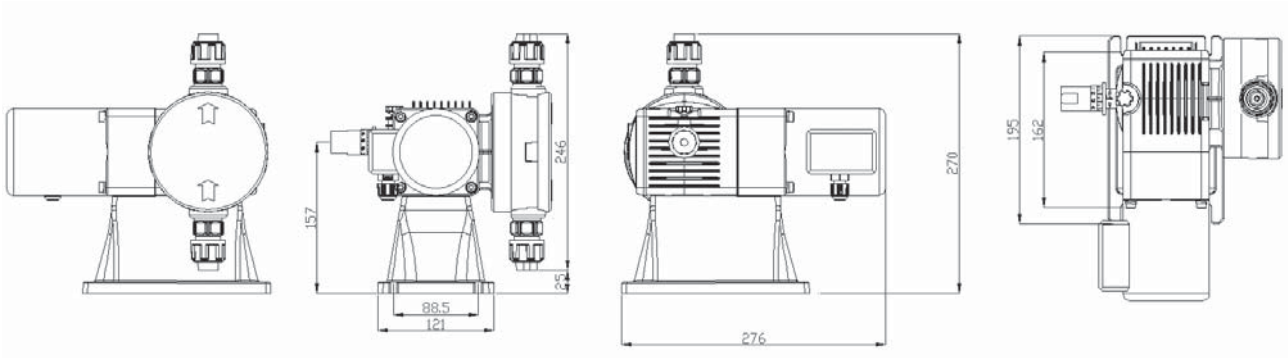

## INSTALLATION KIT (for PVC pump head only)



Injection valve (PVC)  
(G3/8", G1/2")



Foot valve (PVC)



Suction tube  
(PVC, 2m, 8x12)



Delivery tube  
(PE, 3m, 8x12)

	STANDARD		ON REQUEST	
	21	31	24	34
<b>PUMP HEAD</b>	SS316L	PVC	SS316L	PVC
<b>DIAPHRAGM</b>	PTFE			
<b>SEAL</b>	FPM	EPDM		
<b>VALVES</b>	SS316L	Ceramic	SS316L	Ceramic
<b>VALVE SEATS</b>	SS316L	PTFE	SS316L	PTFE

EPDM seal is also available upon request, EPDM seal is applicable to alkaline chemical, and FPM seal is applicable to acid chemical.

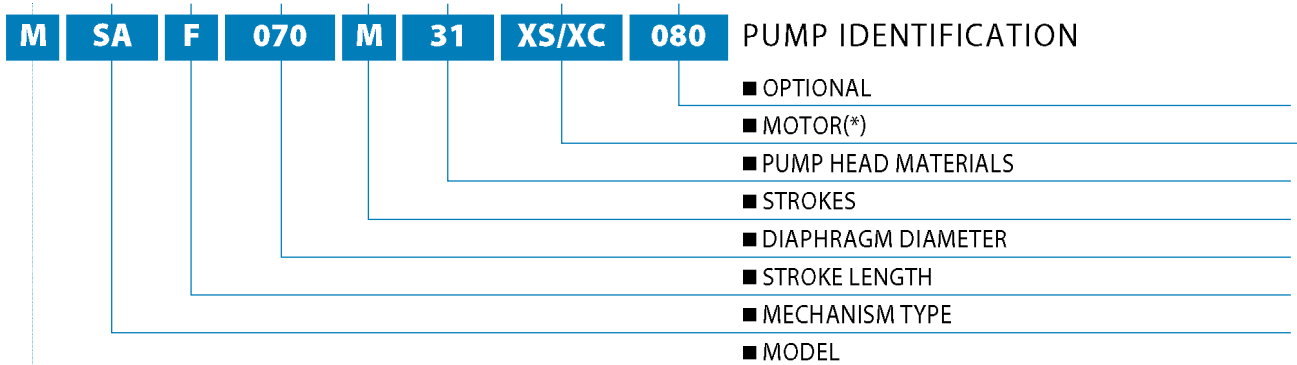

(\*) **XS** 380V-50HZ 3 PHASE – **XC** 220V-50HZ SINGLE PHASE