

TeknoFluida

Your Solutions Partner for
Fluid Technology

TeknoFluida provides dewatering system
for hydraulic, electrohydraulic, lubrication,
and insulating oil application.

DEWATERING SYSTEM

DS 20/40/50
Series

Utilized for Following Applications:

Pulp and Paper
Steel Work
Cement
Power Generation
General Industries



TeknoFluida

TeknoFluida

Dewatering System



Technical Specification

| Dewatering System | DS-M-20 | DS-M-40 | DS-M-50 | |
|--|--|-----------------------|-----------------------|-------|
| Flow rates | 20 L/min | 40 L/min | 50 L/min | |
| Permitted fluids** | Fluids compatibility: ❖ Mineral oils ❖ Synthetic oil / phosphate ester ❖ Insulating oil (phosphate ester) ❖ Other fluids | | | |
| Sealing material | Viton or NBR (other on request) | | | |
| Filtration rating* | 1 µm | 3 µm | 6 µm | 10 µm |
| Pump type, vacuum pump | Rotary vane vacuum pump | | | |
| Pump type, others | Gear pumps | | | |
| Operating pressure | 8...10 bar | | | |
| Permitted pressure at suction port (with hose) | -0.2...+1 bar | | | |
| Operation viscosity range* | 4...1000 mm ² /sec (with heater) | | | |
| Fluid temp. range* | 20...60 °C | | | |
| Ambient temp. range* | 10...40 °C | | | |
| Storage temp. range* | 10...50 °C | | | |
| Relative humidity (ambient)* | Max. 90% non-condensing | | | |
| Power consumption | 4.5 kW/13 A | 16 kW/45 A | 20 kW/55 A | |
| Power supply | Single or three phase | | | |
| Heating power | 4 kW | 11 kW | 13 kW | |
| Accessories | Automatic particle counter or water sensor Special features with coalescer or varnish removal | | | |
| Hoses material | NBR (other on request) | | | |
| Inlet port | G1" | G1 1/2" | G1 1/2" | |
| Outlet port | G1" | G1 1/2" | G1 1/2" | |
| Weight (empty)** | ≈ 250 kg | ≈ 400 kg | ≈ 450 kg | |
| Dimensions** (L x W x H (with heater)) | 1600 x 1020 x 1900 | 1800 x 1200 x 1900 | 1800 x 1200 x 1900 | |

*for other fluids, temperature, viscosities ranges and properties, please contact us
 **true dimensions and weight may different for the finished product



Product Description

Mobile Dewatering System removes gases, water, and solid particulates from fluid. The moisture and oxygen content of the insulation system has a decisive impact on the ageing behavior of power transformers. The Dewatering System (DS) can remove gases, free, and dissolved water and gases from the insulation oil.

This system is a tremendous solution for the dewatering and filtration of large amount of oil which can not be adequately filtered with a mechanical water separation process. With DS Oil Purifier the destructive effects of water in power transformers can be avoided.

Typical transformer problems related to insulating oil related to moisture are:

- ❖ Decreased dielectric strength of oil (breakdown voltage, PD inception level)
- ❖ Accelerated ageing of cellulose
- ❖ Bubble formation at elevated temperatures and wet insulation materials.

Dewatering System has an optional water sensor and particle sensor built-in. Our DS Oil Purifier utilize components made in Germany which ensure first class quality and reliability.

Advantages

Dewatering System process keep insulation oil from water, gases, and solid particulates extremely low in order to obtain:

- ❖ Optimum fluid lifetime
- ❖ High quality protection of components
- ❖ Desire machine operation
- ❖ Minimize maintenance cost due to early failure

Applications

- ❖ Industrial hydraulic and lubrication
- ❖ Steam turbine electro hydraulic control
- ❖ Insulating Oil
- ❖ Slide bearing lubrication

System Diagram

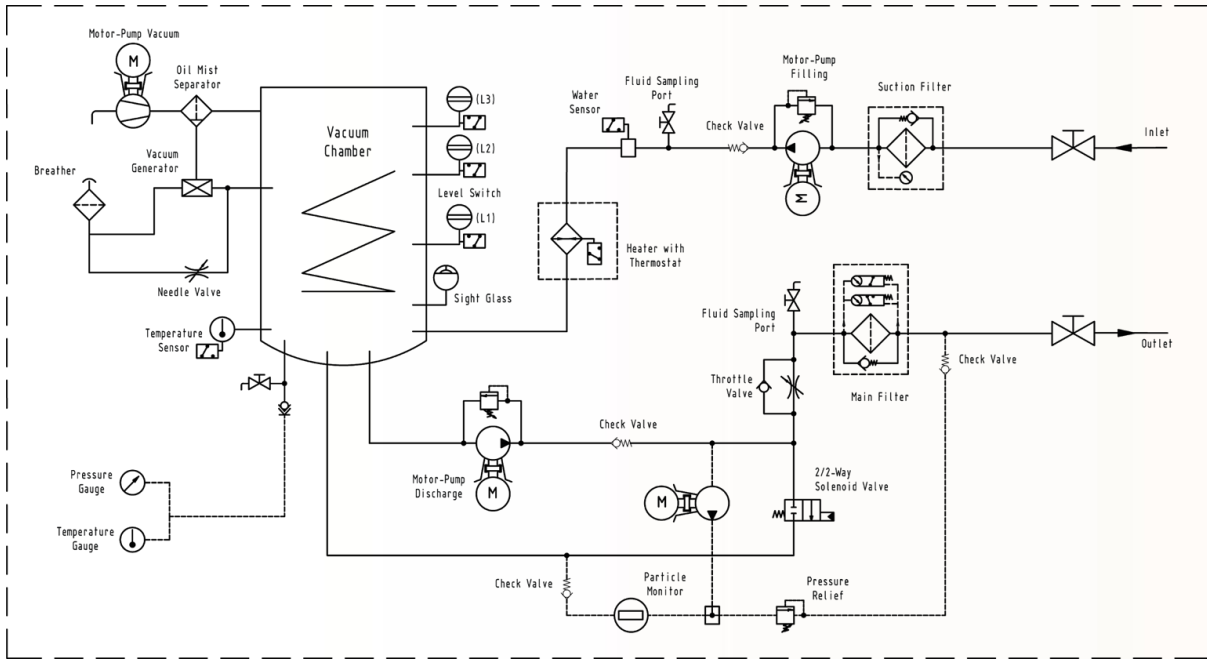

Working Principle

The fluid is conveyed from oil reservoir to the vacuum chamber by a filling pump through the heating column inside the vacuum chamber. The vacuum pump sets up a negative pressure in the vacuum chamber which is needed to boiled dissolved and free water in oil which will then be taken out from the oil by the vacuum pump. The set vacuum pressure is 250-500 mbar. After the oil in the chamber reaches the Max level [L2], the discharge pump is switched on and permanently conveys the fluid out to the outlet from the moment onward. As a result of a greater volume flow of the evacuation pump, the filling level in the vacuum chamber can drop down to the Min level [L1]. Once this is reached, the return valve (2/2-way solenoid valve) opens and a partial volume flow is returned into the heating column. The return valve (2/2-way solenoid valve) closes once again after the max level [L2] has been reached. To control the oil level, a level switch with a float is installed.

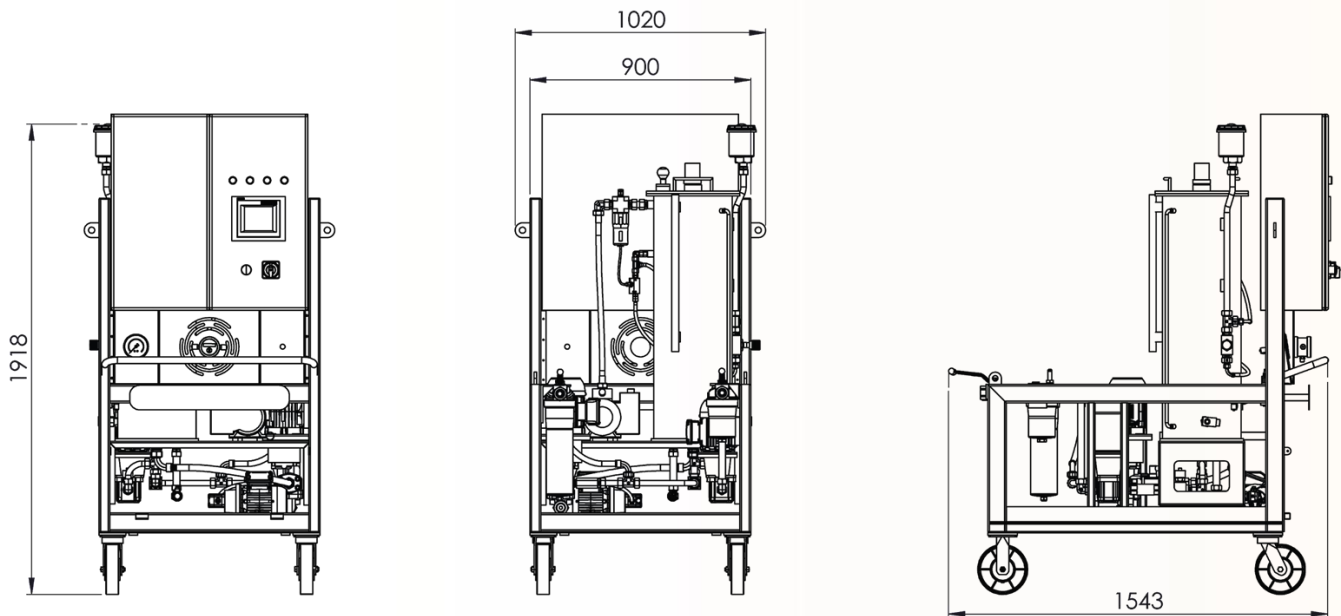

PT. Tekno Fluida Indonesia
 Kawasan Multiguna - Taman Tekno BSD Sektor XI Blok H2 No. 3A
 BSD City , Tangerang 15314. Indonesia
 Tel. : +62-21-75876580
 Fax. : +62-21-75876581
 Email : sales@teknofluida.id
 Site : www.teknofluida.id

TeknoFluida

Order Code

DS - M - 20 - P - 2X / 10 - 03 - F - 02 - WPC

Basic Model

- S = stationary (with feet)
- M = mobile with caster

Nominal Flow Rate*

- 20 = 20 liter/min

Operating Fluids

- L = mineral oil/lubrication oil
- P = phosphate ester/synthetic
- I = insulating oil (transformer oil)

Filter Component Series

Fine Filter

- 25 = 25 micron
- 10 = 10 micron
- 06 = 6 micron

Main Filter

- 06 = 6 micron
- 03 = 3 micron
- 01 = 1 micron

Sealing Materials*

- N = NBR
- F = FKM/Viton

Power Supply

- 01 = 1 phase; 50 Hz; 230V
- 02 = 3 phase; 50 Hz; 380V

Condition Monitoring Sensor and Accessories

- W = standard with water sensor
- WP = water sensor & automatic particle counter
- C = coalescer
- AR = acid removal

*Other flow rate and information source please inform us



WS-1500



TFC-1500

Filter Element Rating

In a hydraulic or lubrication system, filter main duty is to achieve a particle contamination to the required cleanliness level and keeping the level constantly during a long period. For identification of the solids contaminant in industrial hydraulic, the reading of particles quantity according to the ISO Code 4406. With the new definition of the test dust and number of particles, the standard ISO 4406 has been revised in 1987.

This standard has been newly published as ISO 4406 in 1999. The new edition now uses a 3-digit code for particles 4 μm(c), > 6 μm(c), und > 14 μm(c). The particle sizes > 6 μm(c) and > 14 μm(c) corresponds to approx. 0.9 μm referring to the obsolete. In the following, the achieved cleanliness class with PulseShield™ Technology filter elements for all standardized ranges are stated. These values are based on long-term experiences with filter sizing and are considered as an approximate value.

| Cleanliness Class According ISO 4406:1999 | | |
|---|--------------|-------------------|
| Filter Rating | Bx(c) ≥ 1000 | Cleanliness Class |
| Pi 0145 PS 1 | 2,5 | 07/03/01 |
| Pi 2145 PS 3 | 5 | 12/07/02 |
| Pi 31 45 PS 10 | 12 | 16/13/04 |
| Pi 4145 PS 25 | 24 | 23/19/13 |
| Pi 5145 PS 6 | 9 | 15/11/04 |